

# EMC Test Report

Report No.: AGC01180160702EE02

**PRODUCT DESIGNATION** : IP Phone  
**BRAND NAME** : ATCOM  
**MODEL NAME** : A41W, A40W, A41, A40  
**CLIENT** : ATCOM TECHNOLOGY CO., LIMITED  
**DATE OF ISSUE** : July 26, 2016  
**STANDARD(S)** : EN 55022:2010/AC:2011  
EN 61000-3-2:2014  
EN 61000-3-3:2013  
EN 55024:2010  
**REPORT VERSION** : V1.0

Attestation of Global Compliance (Shenzhen) Co., Ltd



**CAUTION:**

This report shall not be reproduced except in full without the written permission of the test laboratory and shall not be quoted out of context.



The results shown in this test report refer only to the sample(s) tested unless otherwise stated and the sample(s) are retained for 30 days only. The document is issued by AGC, this document cannot be reproduced except in full with our prior written permission. The document is available on request and the brief information for its validation can be assessable and confirmed at <http://www.agc-cert.com>

**Report Revise Record**

Report Version	Revise Time	Issued Date	Valid Version	Notes
V1.0	/	July 26, 2016	Valid	Original Report

The results shown in this test report refer only to the sample(s) tested unless otherwise stated and the sample(s) are retained for 30 days only. The document is issued by AGC, this document cannot be reproduced except in full with our prior written permission. The document is available on request and the brief information for its validation can be assessable and confirmed at <http://www.agc-cert.com>



**TABLE OF CONTENTS**

<b>1. VERIFICATION OF CONFORMITY</b> .....	<b>5</b>
<b>2. SYSTEM DESCRIPTION</b> .....	<b>6</b>
<b>3. MEASUREMENT UNCERTAINTY</b> .....	<b>6</b>
<b>4. PRODUCT INFORMATION</b> .....	<b>7</b>
<b>5. SUPPORT EQUIPMENT</b> .....	<b>8</b>
<b>6. TEST FACILITY</b> .....	<b>9</b>
<b>7. EN 55022 LINE CONDUCTED EMISSION TEST</b> .....	<b>11</b>
7.1. LIMITS OF LINE CONDUCTED EMISSION TEST .....	11
7.2. BLOCK DIAGRAM OF TEST SETUP .....	11
7.3. PROCEDURE OF LINE CONDUCTED EMISSION TEST .....	12
7.4. TEST RESULT OF LINE CONDUCTED EMISSION TEST .....	13
<b>8. EN 55022 RADIATED EMISSION TEST</b> .....	<b>16</b>
8.1. LIMITS OF RADIATED DISTURBANCES.....	16
8.2. BLOCK DIAGRAM OF TEST SETUP .....	16
8.3. PROCEDURE OF RADIATED EMISSION TEST .....	17
8.4. TEST RESULT OF RADIATED EMISSION TEST .....	18
<b>9. EN 61000-3-2 POWER HARMONICS TEST</b> .....	<b>20</b>
9.1. BLOCK DIAGRAM OF TEST SETUP .....	20
9.2. RESULT .....	20
<b>10. EN 61000-3-3 VOLTAGE FLUCTUATION / FLICKER TEST</b> .....	<b>21</b>
10.1. BLOCK DIAGRAM OF TEST SETUP .....	21
10.2. RESULT .....	22
<b>11. EN 61000-4-2 ESD IMMUNITY TEST</b> .....	<b>23</b>
11.1. BLOCK DIAGRAM OF TEST SETUP.....	23
11.2. TEST PROCEDURE .....	24
11.3. PERFORMANCE & RESULT .....	25
<b>12. EN 61000-4-3 RS IMMUNITY TEST</b> .....	<b>26</b>
12.1. BLOCK DIAGRAM OF TEST SETUP .....	26
12.2. TEST PROCEDURE .....	27
12.3. PERFORMANCE & RESULT .....	27
<b>13. EN 61000-4-4 EFT IMMUNITY TEST</b> .....	<b>28</b>
13.1. BLOCK DIAGRAM OF TEST SETUP .....	28
13.2. TEST PROCEDURE .....	29
13.3. PERFORMANCE & RESULT .....	29
<b>14. EN 61000-4-5 SURGE IMMUNITY TEST</b> .....	<b>30</b>

The results shown in this test report refer only to the sample(s) tested unless otherwise stated and the sample(s) are retained for 30 days only. The document is issued by AGC, this document cannot be reproduced except in full with our prior written permission. The document is available on request and the brief information for its validation can be assessable and confirmed at <http://www.agc-cert.com>

14.1. BLOCK DIAGRAM OF TEST SETUP .....	30
14.2. TEST PROCEDURE .....	31
14.3. PERFORMANCE & RESULT .....	31
<b>15. EN 61000-4-6 CS IMMUNITY TEST .....</b>	<b>32</b>
15.1. BLOCK DIAGRAM OF TEST SETUP .....	32
15.2. TEST PROCEDURE .....	33
15.3. PERFORMANCE & RESULT .....	33
<b>16. EN 61000-4-11 DIPS IMMUNITY TEST .....</b>	<b>34</b>
16.1. BLOCK DIAGRAM OF TEST SETUP .....	34
16.2. TEST PROCEDURE .....	35
16.3. INTERPRETATION .....	35
<b>APPENDIX A: PHOTOGRAPHS OF TEST SETUP .....</b>	<b>36</b>
<b>APPENDIX B: PHOTOGRAPHS OF EUT .....</b>	<b>41</b>

The results shown in this test report refer only to the sample(s) tested unless otherwise stated and the sample(s) are retained for 30 days only. The document is issued by AGC, this document cannot be reproduced except in full with our prior written permission. The document is available on request and the brief information for its validation can be assessable and confirmed at <http://www.agc-cert.com>



**1. VERIFICATION OF CONFORMITY**

<b>Applicant</b>	ATCOM TECHNOLOGY CO., LIMITED
<b>Address</b>	FL2, Block3, Huangguan Industry Park #21 Tai Ran 9th Rd, Futian, Shenzhen City, China
<b>Manufacturer</b>	ATCOM TECHNOLOGY CO., LIMITED
<b>Address</b>	FL2, Block3, Huangguan Industry Park #21 Tai Ran 9th Rd, Futian, Shenzhen City, China
<b>Product Designation</b>	IP Phone
<b>Brand Name</b>	ATCOM
<b>Test Model</b>	A41W,
<b>Series Model</b>	A40W,A41,A40
<b>Model Difference</b>	All are the same except the model name and POE function. A41W and A41 support POE function, but others didn't.
<b>Date of test</b>	July 18, 2016 to July 25, 2016
<b>Deviation</b>	None
<b>Condition of Test Sample</b>	Normal
<b>Test Result</b>	Pass
<b>Report Template</b>	AGCRT-EC-IT/AC(2013-03-01)

The above equipment was tested by Attestation of Global Compliance (Shenzhen) Co., Ltd. for compliance with the requirements set forth in the Technical Standards mentioned above. This said equipment in the configuration described in this report shows the maximum emission levels emanating from equipment and the level of the immunity endurance of the equipment are within the compliance requirements. The test results of this report relate only to the tested sample identified in this report.

Tested by

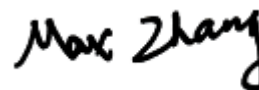

Max Zhang(Zhang Yi) July 26, 2016

Reviewed by

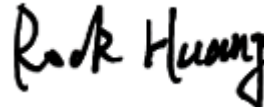

Rock Huang(Huang Dinglue) July 26, 2016

Approved by

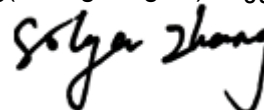

 Solger Zhang(Zhang Hongyi) July 26, 2016  
 Authorized Officer

The results shown in this test report refer only to the sample(s) tested unless otherwise stated and the sample(s) are retained for 30 days only. The document is issued by AGC, this document cannot be reproduced except in full with our prior written permission. The document is available on request and the brief information for its validation can be assessable and confirmed at <http://www.agc-cert.com>

## 2. SYSTEM DESCRIPTION

### TEST MODE DESCRIPTION

NO.	TEST MODE DESCRIPTION	WORST
1	IP calling with LAN connected	V

Note: 1. V means EMI worst mode

## 3. MEASUREMENT UNCERTAINTY

The uncertainty is calculated using the methods suggested in the "Guide to the Expression of Uncertainty in measurement" (GUM) published by ISO.

- Uncertainty of Conducted Emission,  $U_c = \pm 2.75\text{dB}$
- Uncertainty of Radiated Emission,  $U_c = \pm 3.2\text{dB}$

The results shown in this test report refer only to the sample(s) tested unless otherwise stated and the sample(s) are retained for 30 days only. The document is issued by AGC, this document cannot be reproduced except in full with our prior written permission. The document is available on request and the brief information for its validation can be assessable and confirmed at <http://www.agc-cert.com>



**4. PRODUCT INFORMATION**

<b>Housing Type</b>	Plastic and Metal
<b>Adapter Input Rating</b>	AC 100-240V 200mAh
<b>Adapter Output Rating</b>	DC 5V 1A

**I/O Port Information ( Applicable  Not Applicable)**

I/O Port of EUT			
I/O Port Type	Number	Cable Description	Tested With
RJ45	3	0.8m Unshielded	3
DC In	1	0.8m Unshielded	1
Headset	1	0.8m Unshielded	1
Handset	1	0.8m Unshielded	1

The results shown in this test report refer only to the sample(s) tested unless otherwise stated and the sample(s) are retained for 30 days only. The document is issued by AGC, this document cannot be reproduced except in full with our prior written permission. The document is available on request and the brief information for its validation can be assessable and confirmed at <http://www.agc-cert.com>

### 5. SUPPORT EQUIPMENT

Device Type	Manufacturer	Model Name	Data Cable	Power Cable
Router	TP link	TP-808A	--	Router
PC	Acer	4741G	--	PC

The results shown in this test report refer only to the sample(s) tested unless otherwise stated and the sample(s) are retained for 30 days only. The document is issued by AGC, this document cannot be reproduced except in full with our prior written permission. The document is available on request and the brief information for its validation can be assessable and confirmed at <http://www.agc-cert.com>





**6. TEST FACILITY**

<b>Site</b>	Attestation of Global Compliance (Shenzhen) Co., Ltd
<b>Location</b>	B112-B113, Building 12, Baoan Building Materials Center, No.1 of Xixiang Inner Ring Road, Baoan District, Shenzhen, Guangdong, P.R.China

**TEST EQUIPMENT OF CONDUCTED EMISSION TEST**

Equipment	Manufacturer	Model	S/N	Cal. Date	Cal. Due
TEST RECEIVER	R&S	ESCI	100096	2015.07.31	2016.07.30
LISN	R&S	ESH2-Z5	100086	2015.09.05	2016.09.04

**TEST EQUIPMENT OF RADIATED EMISSION TEST**

Equipment	Manufacturer	Model	S/N	Cal. Date	Cal. Due
TEST RECEIVER	R&S	ESPI	101206	2015.07.31	2016.07.30
ANTENNA	SCHWARZBECK	VULB9168	494	2016.03.01	2018.02.28

**TEST EQUIPMENT OF POWER HARMONICS / VOLTAGE FLUCTUATION / FLICKER TEST**

Equipment	Manufacturer	Model	S/N	Cal. Date	Cal. Due
Signal Conditioning Unit	Schaffner	CCN1000-1	72431	2015.08.31	2016.08.30
AC Source	Schaffner	NSG1007	56825	2015.08.31	2016.08.30

**TEST EQUIPMENT OF ESD TEST**

Equipment	Manufacturer	Model	S/N	Cal. Date	Cal. Due
ESD Simulator	Schaffner	NSG 438	782	2015.11.18	2016.11.17

**TEST EQUIPMENT OF SURGE/EFT/DIPS IMMUNITY TEST**

Equipment	Manufacturer	Model	S/N	Cal. Date	Cal. Due
EFT/Surge Generator	Schaffner	Modula 6150	34437	2015.08.31	2016.08.30

The results shown in this test report refer only to the sample(s) tested unless otherwise stated and the sample(s) are retained for 30 days only. The document is issued by AGC, this document cannot be reproduced except in full with our prior written permission. The document is available on request and the brief information for its validation can be assessable and confirmed at <http://www.agc-cert.com>

**TEST EQUIPMENT OF RS IMMUNITY TEST**

Description	Manufacturer	Model	Identifier	Cal. Date	Cal. Due
SIGNAL GENERATOR	R&S	E4421B	102525	2016.07.01	2017.06.30
ANTENNA	SCHWARZBECK	VULB9168	VULB9168-494	2016.03.01	2018.02.28
POWER SENSOR	R&S	URV5-Z4	100124	2015.07.29	2016.07.28
POWER METER	R&S	NRVD	832378/027	2015.07.29	2016.07.28
POWER AMPLIFIER	KALMUS	7100LC	N/A	2016.07.01	2017.06.30
RF AMPLIFIER	Milmega	AS0104-55_55	1004793	2016.07.01	2017.06.30
HORN ANTENNA	ETS LINDGREN	3117	N/A	2016.03.01	2018.02.28

**TEST EQUIPMENT OF CS IMMUNITY TEST**

Description	Manufacturer	Model	S/N	Cal. Date	Cal. Due
Power Amplifier	AR	75A250	18464	2016.07.01	2017.06.30
CDN	Schaffner	M016	21264	2015.09.05	2016.09.04
6dB attenuator	JWF	50FHC-006-50	N/A	2016.03.01	2017.02.28
Electromagnetic Injection Clamp	Luthi	EM101	35773	2015.09.01	2016.08.31
Power Sensor	R&S	URV5-Z4	100124	2015.07.29	2016.07.28
Power Meter	R&S	NRVD	832378/027	2015.07.29	2016.07.28
Signal Generator	R&S	SML01	104228	2016.07.01	2017.06.30

The results shown in this test report refer only to the sample(s) tested unless otherwise stated and the sample(s) are retained for 30 days only. The document is issued by AGC, this document cannot be reproduced except in full with our prior written permission. The document is available on request and the brief information for its validation can be assessable and confirmed at <http://www.agc-cert.com>

## 7. EN 55022 LINE CONDUCTED EMISSION TEST

### 7.1. LIMITS OF LINE CONDUCTED EMISSION TEST

Frequency	Maximum RF Line Voltage	
	Q.P.( dBuV)	Average( dBuV)
150kHz-500kHz	66-56	56-46
500kHz-5MHz	56	46
5MHz-30MHz	60	50

**Note:**

1. The lower limit shall apply at the transition frequency.
2. The limit decreases linearly with the logarithm of the frequency in the range 0.15 MHz to 0.50MHz.

### 7.2. BLOCK DIAGRAM OF TEST SETUP

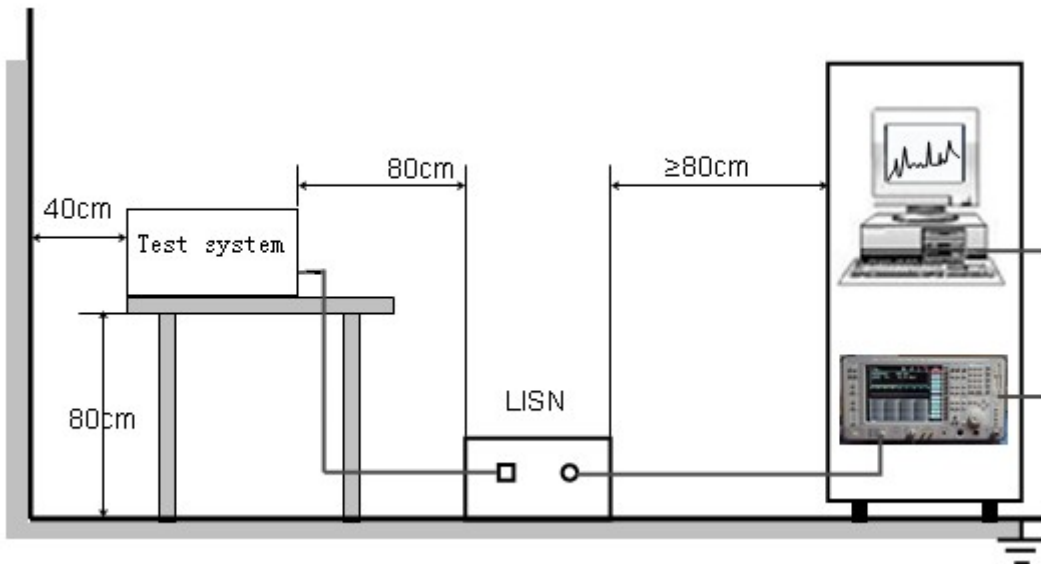

The results shown in this test report refer only to the sample(s) tested unless otherwise stated and the sample(s) are retained for 30 days only. The document is issued by AGC, this document cannot be reproduced except in full with our prior written permission. The document is available on request and the brief information for its validation can be assessable and confirmed at <http://www.agc-cert.com>

### 7.3. PROCEDURE OF LINE CONDUCTED EMISSION TEST

- (1) The equipment was set up as per the test configuration to simulate typical actual usage per the user's manual. When the EUT is a tabletop system, a wooden table with a height of 0.8 meters is used and is placed on the ground plane as per EN55022 (see Test Facility for the dimensions of the ground plane used). When the EUT is a floor-standing equipment, it is placed on the ground plane which has a 3-12 mm non-conductive covering to insulate the EUT from the ground plane.
- (2) Support equipment, if needed, was placed as per EN55022.
- (3) All I/O cables were positioned to simulate typical actual usage as per EN55022.
- (4) The EUT received AC230V/50Hz power through a Line Impedance Stabilization Network (LISN) which supplied power source and was grounded to the ground plane.
- (5) All support equipments received power from a second LISN supplying power of AC 230V/50Hz, if any.
- (6) The EUT test program was started. Emissions were measured on each current carrying line of the EUT using a spectrum Analyzer / Receiver connected to the LISN powering the EUT. The LISN has two monitoring points: Line 1 (Hot Side) and Line 2 (Neutral Side). Two scans were taken: one with Line 1 connected to Analyzer / Receiver and Line 2 connected to a 50 ohm load; the second scan had Line 1 connected to a 50 ohm load and Line 2 connected to the Analyzer / Receiver.
- (7) Analyzer / Receiver scanned from 150 kHz to 30 MHz for emissions in each of the test modes.
- (8) During the above scans, the emissions were maximized by cable manipulation.
- (9) A scan was taken on both power lines, Line 1 and Line 2, recording at least the six highest emissions.
- (10) Emission frequency and amplitude were recorded into a computer in which correction factors were used to calculate the emission level and compare reading to the applicable limit. If EUT emission level was less -2dB to the A.V. limit in Peak mode, then the emission signal was re-checked using Q.P and Average detector.

The results shown in this test report refer only to the sample(s) tested unless otherwise stated and the sample(s) are retained for 30 days only. The document is issued by AGC, this document cannot be reproduced except in full with our prior written permission. The document is available on request and the brief information for its validation can be assessable and confirmed at <http://www.agc-cert.com>

**7.4. TEST RESULT OF LINE CONDUCTED EMISSION TEST**

The test modes were carried out for all operation modes

The worst test data (mode 1) was showed as the follow:

AT MAIN PORT  
LINE CONDUCTED EMISSION TEST-L

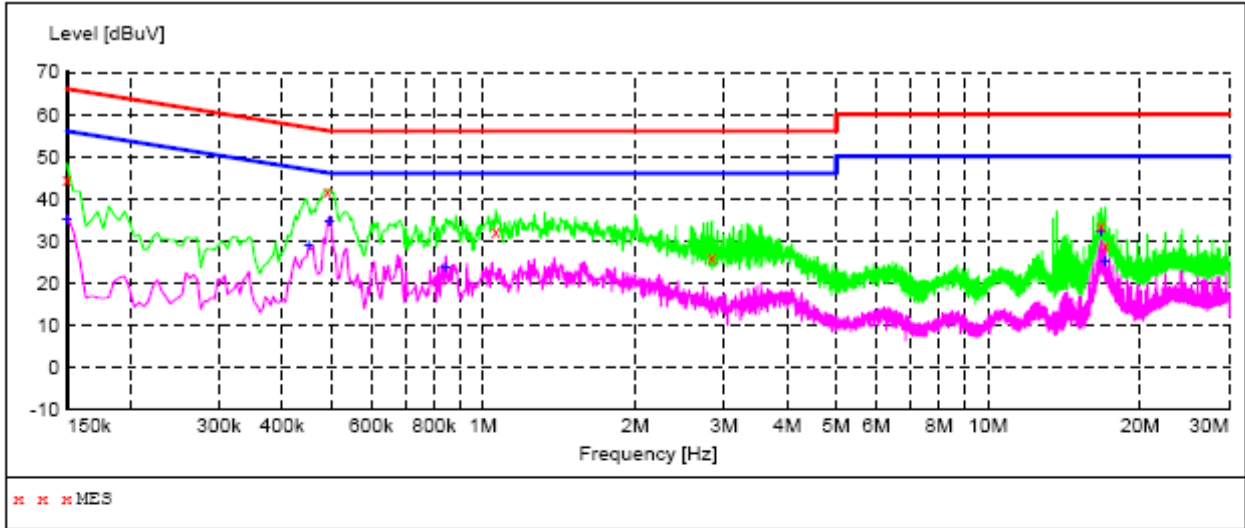

**MEASUREMENT RESULT:**

Frequency MHz	Level dBuV	Transd dB	Limit dBuV	Margin dB	Detector	Line	PE
0.150000	44.40	3.7	66	21.6	QP	L1	FLO
0.492000	41.50	3.6	56	14.6	QP	L1	FLO
1.059000	32.10	3.7	56	23.9	QP	L1	FLO
2.836500	26.10	3.8	56	29.9	QP	L1	FLO
16.705500	33.60	4.1	60	26.4	QP	L1	FLO
17.029500	28.70	4.1	60	31.3	QP	L1	FLO

**MEASUREMENT RESULT:**

Frequency MHz	Level dBuV	Transd dB	Limit dBuV	Margin dB	Detector	Line	PE
0.150000	35.20	3.7	56	20.8	AV	L1	FLO
0.451500	28.90	3.6	47	17.9	AV	L1	FLO
0.496500	34.60	3.6	46	11.5	AV	L1	FLO
0.843000	23.80	3.7	46	22.2	AV	L1	FLO
16.714500	32.40	4.1	50	17.6	AV	L1	FLO
17.034000	25.10	4.1	50	24.9	AV	L1	FLO

**RESULT: PASS**

The results shown in this test report refer only to the sample(s) tested unless otherwise stated and the sample(s) are retained for 30 days only. The document is issued by AGC, this document cannot be reproduced except in full with our prior written permission. The document is available on request and the brief information for its validation can be assessable and confirmed at <http://www.agc-cert.com>



LINE CONDUCTED EMISSION TEST-N

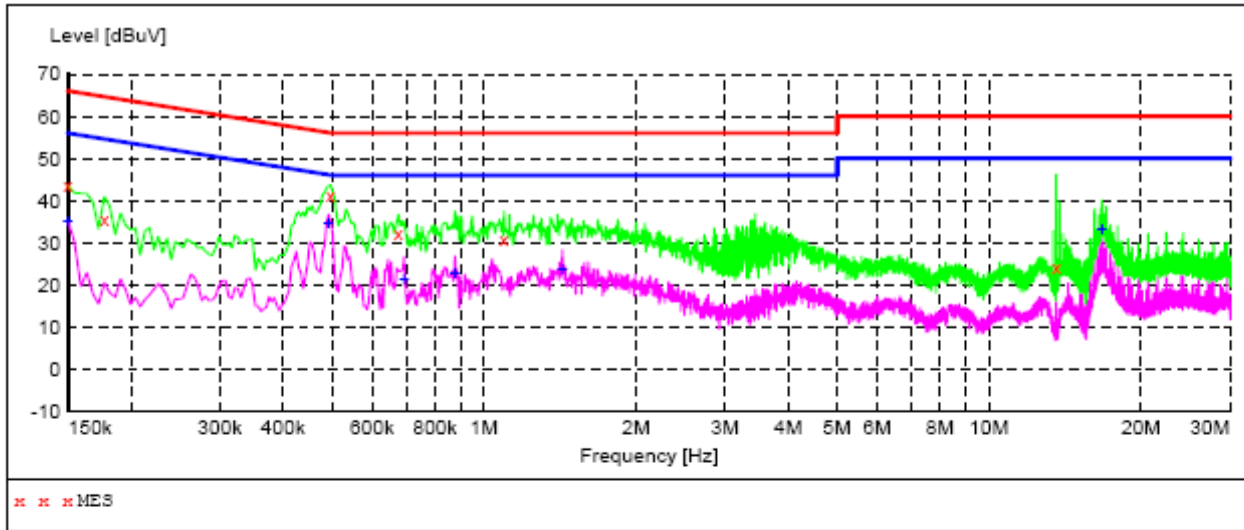

MEASUREMENT RESULT:

Frequency MHz	Level dBuV	Transd dB	Limit dBuV	Margin dB	Detector	Line	PE
0.150000	43.50	3.7	66	22.5	QP	N	FLO
0.177000	35.50	3.6	65	29.1	QP	N	FLO
0.496500	41.40	3.6	56	14.7	QP	N	FLO
0.676500	32.40	3.7	56	23.6	QP	N	FLO
1.095000	30.80	3.7	56	25.2	QP	N	FLO
13.573500	24.30	4.0	60	35.7	QP	N	FLO

MEASUREMENT RESULT:

Frequency MHz	Level dBuV	Transd dB	Limit dBuV	Margin dB	Detector	Line	PE
0.150000	35.30	3.7	56	20.7	AV	N	FLO
0.492000	34.80	3.6	46	11.3	AV	N	FLO
0.694500	21.30	3.7	46	24.7	AV	N	FLO
0.874500	22.90	3.7	46	23.1	AV	N	FLO
1.428000	23.50	3.7	46	22.5	AV	N	FLO
16.714500	33.10	4.1	50	16.9	AV	N	FLO

RESULT: PASS

The results shown in this test report refer only to the sample(s) tested unless otherwise stated and the sample(s) are retained for 30 days only. The document is issued by AGC, this document cannot be reproduced except in full with our prior written permission. The document is available on request and the brief information for its validation can be assessable and confirmed at <http://www.agc-cert.com>



AT TELECOMMUNICATION PORT

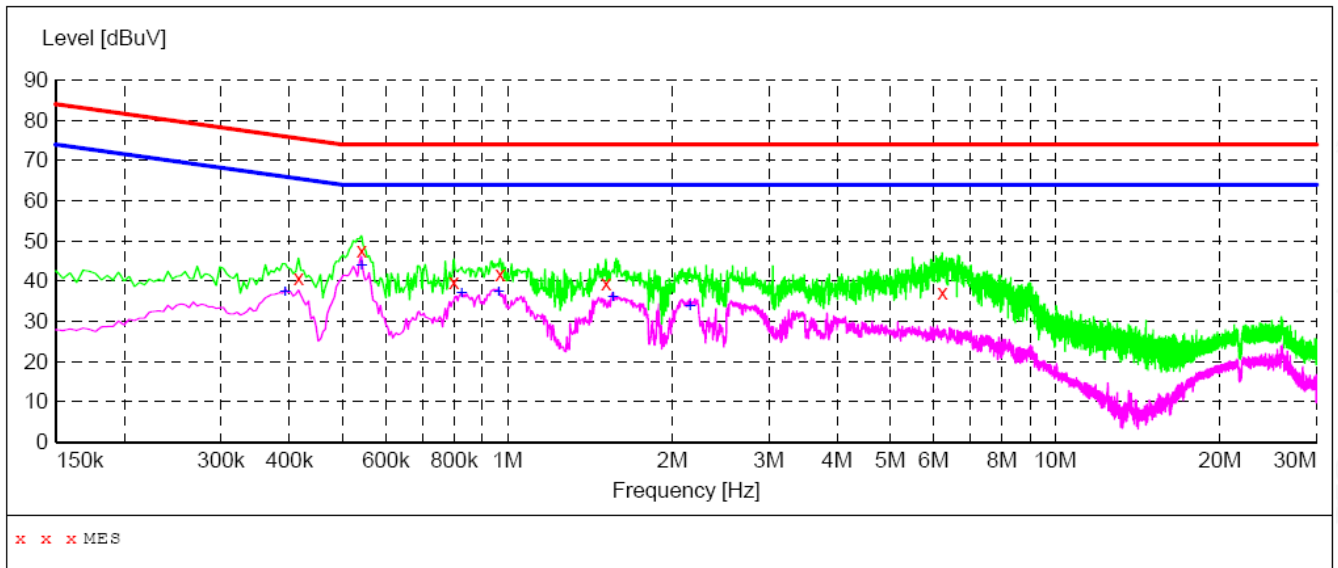

**MEASUREMENT RESULT:**

Frequency	Level	Transd	Limit	Margin	Detector
MHz	dBuV	dB	dBuV	dB	
0.415500	40.80	3.6	76	34.7	QP
0.541500	47.80	3.6	74	26.2	QP
0.798000	39.90	3.7	74	34.1	QP
0.969000	41.90	3.7	74	32.1	QP
1.513500	39.60	3.7	74	34.4	QP
6.225000	37.20	3.9	74	36.8	QP

**MEASUREMENT RESULT:**

Frequency	Level	Transd	Limit	Margin	Detector
MHz	dBuV	dB	dBuV	dB	
0.393000	37.40	3.6	66	28.6	AV
0.541500	43.80	3.6	64	20.2	AV
0.825000	36.80	3.7	64	27.2	AV
0.964500	37.40	3.7	64	26.6	AV
1.558500	36.00	3.7	64	28.0	AV
2.157000	33.80	3.7	64	30.2	AV

**RESULT: PASS**

The results shown in this test report refer only to the sample(s) tested unless otherwise stated and the sample(s) are retained for 30 days only. The document is issued by AGC, this document cannot be reproduced except in full with our prior written permission. The document is available on request and the brief information for its validation can be assessable and confirmed at <http://www.agc-cert.com>



## 8. EN 55022 RADIATED EMISSION TEST

### 8.1. LIMITS OF RADIATED DISTURBANCES

#### AT 10M DISTANCES

Frequency (MHz)	Distance (m)	Maximum Field Strength Limit (dBuV/m Q.P.)
30-230	10	30.00
230-1000	10	37.00

#### AT 3M DISTANCES

Frequency (MHz)	Distance (m)	Maximum Field Strength Limit (dBuV/m Q.P.)
30-230	3	40.00
230-1000	3	47.00

Note: The lower limit shall apply at the transition frequency.

### 8.2. BLOCK DIAGRAM OF TEST SETUP

System Diagram of Connections between EUT and Simulators

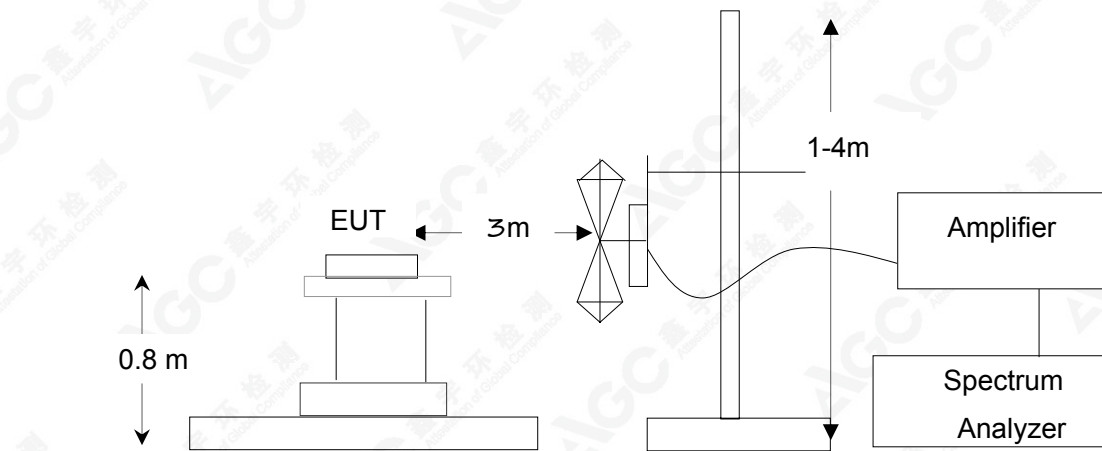

The results shown in this test report refer only to the sample(s) tested unless otherwise stated and the sample(s) are retained for 30 days only. The document is issued by AGC; this document cannot be reproduced except in full with our prior written permission. The document is available on request and the brief information for its validation can be assessable and confirmed at <http://www.agc-cert.com>



### 8.3. PROCEDURE OF RADIATED EMISSION TEST

- (1) The equipment was set up as per the test configuration to simulate typical actual usage per the user's manual. When the EUT is a tabletop system, a wooden turntable with a height of 0.8 meters is used which is placed on the ground plane as per EN 55022 (see Test Facility for the dimensions of the ground plane used). When the EUT is a floor-standing equipment, it is placed on the ground plane which has a 3-12 mm non-conductive covering to insulate the EUT from the ground plane.
- (2) Support equipment, if needed, was placed as per EN 55022.
- (3) All I/O cables were positioned to simulate typical actual usage as per EN 55022.
- (4) The EUT received AC230V/50Hz power through the outlet socket under the turntable. All support equipments received AC230V/50Hz power from socket under the turntable, if any.
- (5) The antenna was placed at 3 meter away from the EUT as stated in EN 55022. The antenna connected to the Analyzer via a cable and at times a pre-amplifier would be used.
- (6) The Analyzer / Receiver quickly scanned from 30MHz to 1000MHz. The EUT test program was started. Emissions were scanned and measured rotating the EUT to 360 degrees and positioning the antenna 1 to 4 meters above the ground plane, in both the vertical and the horizontal polarization, to maximize the emission reading level.
- (7) The test mode(s) were scanned during the test:
- (8) Recorded at least the six highest emissions. Emission frequency, amplitude, antenna position, polarization and turntable position were recorded into a computer in which correction factors were used to calculate the emission level and compare reading to the applicable limit and Q.P./Peak reading is presented.

The results shown in this test report refer only to the sample(s) tested unless otherwise stated and the sample(s) are retained for 30 days only. The document is issued by AGC, this document cannot be reproduced except in full with our prior written permission. The document is available on request and the brief information for its validation can be assessable and confirmed at <http://www.agc-cert.com>

**8.4. TEST RESULT OF RADIATED EMISSION TEST**

The test modes were carried out for all operation modes  
The worst test data (mode 1) was showed as the follow:

**RADIATED EMISSION BELOW 1GHZ- HORIZONTAL**

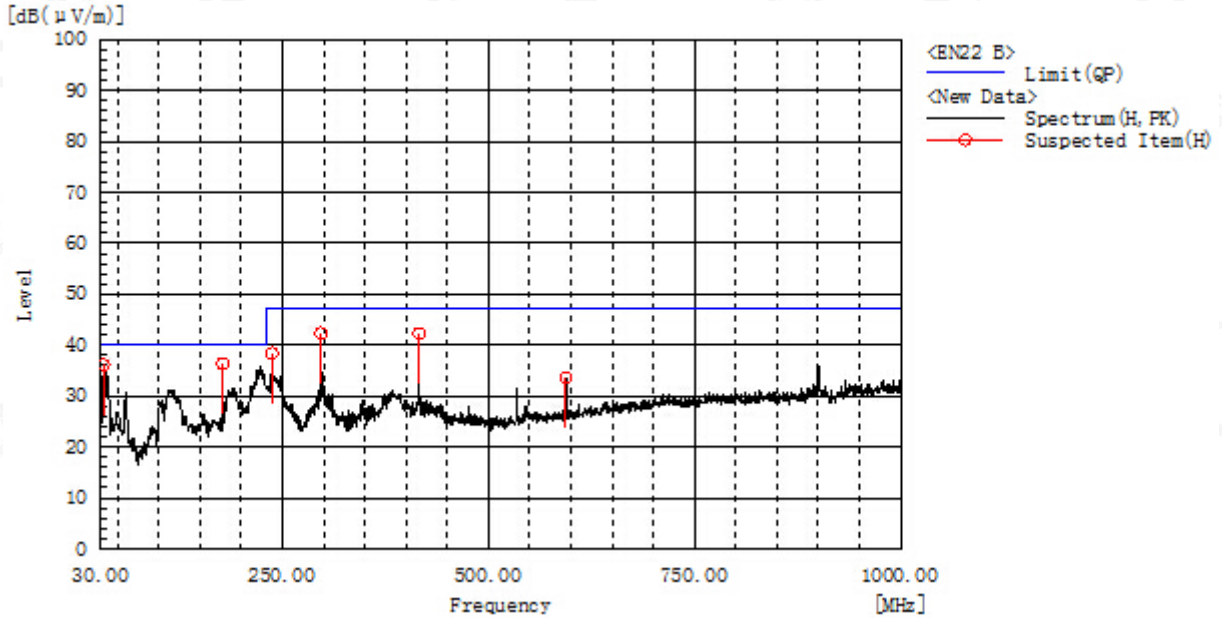

Frequency MHz	Polarization	Reading dB(uV)	Factor dB (1/m)	Level dB(uV/m) PK	Limit dB(uV/m) QP	Margin dB	Pass/Fail	Height cm	Angle deg
33.395	H	22.1	14.1	36.2	40.0	3.8	Pass	100.0	160.5
177.925	H	22.9	13.5	36.4	40.0	3.6	Pass	100.0	43.2
237.580	H	25.4	13.1	38.5	47.0	8.5	Pass	100.0	351.0
296.750	H	27.7	14.7	42.4	47.0	4.6	Pass	100.0	116.1
416.060	H	24.5	17.8	42.3	47.0	4.7	Pass	200.0	110.5
594.055	H	12.2	21.4	33.6	47.0	13.4	Pass	100.0	169.9

**RESULT: PASS**

The results shown in this test report refer only to the sample(s) tested unless otherwise stated and the sample(s) are retained for 30 days only. The document is issued by AGC, this document cannot be reproduced except in full with our prior written permission. The document is available on request and the brief information for its validation can be assessable and confirmed at <http://www.agc-cert.com>



RADIATED EMISSION BELOW 1GHZ- VERTICAL

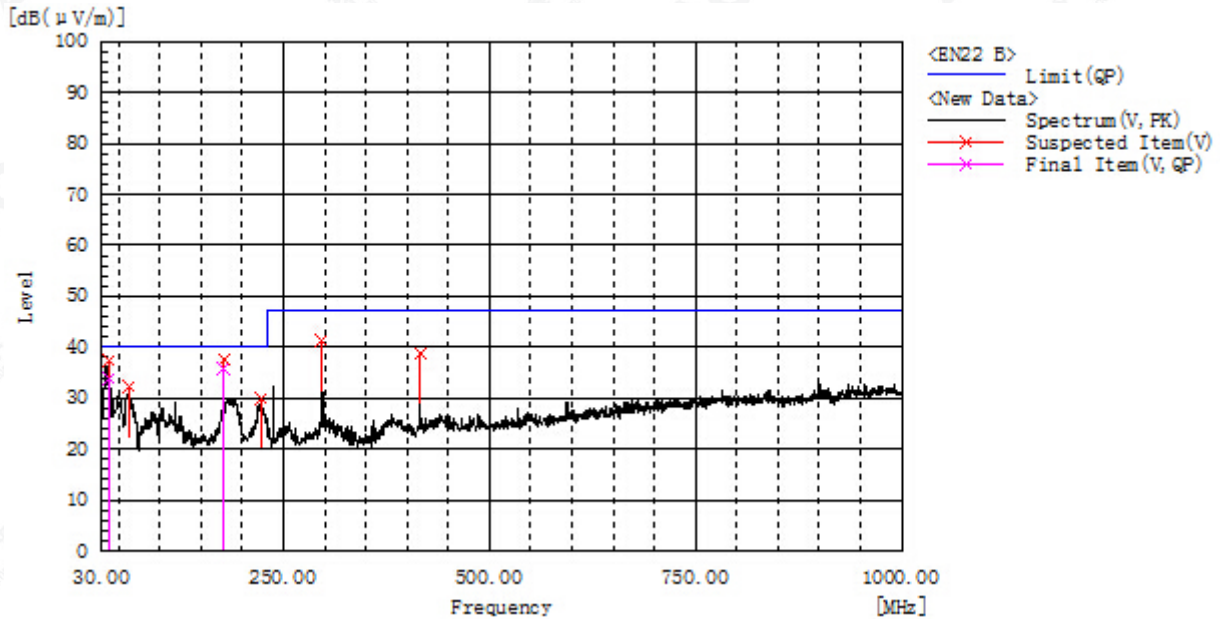

Frequency MHz	Polarization	Reading dB(uV)	Factor dB (1/m)	Level dB(uV/m) PK	Limit dB(uV/m) QP	Margin dB	Pass/Fail	Height cm	Angle deg
62.980	V	16.9	15.3	32.2	40.0	7.8	Pass	100.0	236.5
223.515	V	17.1	12.9	30.0	40.0	10.0	Pass	100.0	220.8
296.750	V	26.6	14.7	41.3	47.0	5.7	Pass	200.0	15.7
416.060	V	20.9	17.8	38.7	47.0	8.3	Pass	100.0	341.8

Frequency MHz	Polarization	Reading dB(uV) QP	Factor dB (1/m)	Level dB(uV/m) QP	Limit dB(uV/m) QP	Margin dB	Pass/Fail	Height cm	Angle deg
38.710	V	16.9	16.9	33.8	40.0	6.2	Pass	200.0	0.0
177.925	V	22.3	13.5	35.8	40.0	4.2	Pass	100.0	0.0

**RESULT: PASS**

Remark: which above 1GHz are attenuated more than 20dB below the permissible limits or the field strength is too small to be measured.

The results shown in this test report refer only to the sample(s) tested unless otherwise stated and the sample(s) are retained for 30 days only. The document is issued by AGC, this document cannot be reproduced except in full with our prior written permission. The document is available on request and the brief information for its validation can be assessable and confirmed at <http://www.agc-cert.com>



**9. EN 61000-3-2 POWER HARMONICS TEST**  
**POWER HARMONICS MEASUREMENT**

Port	AC mains
Basic Standard	EN 61000-3-2
Limits	<input checked="" type="checkbox"/> CLASS A ; <input type="checkbox"/> CLASS B ; <input type="checkbox"/> CLASS C ; <input type="checkbox"/> CLASS D
Tester	Max
Temperature	25°C
Humidity	55%

**9.1. BLOCK DIAGRAM OF TEST SETUP**

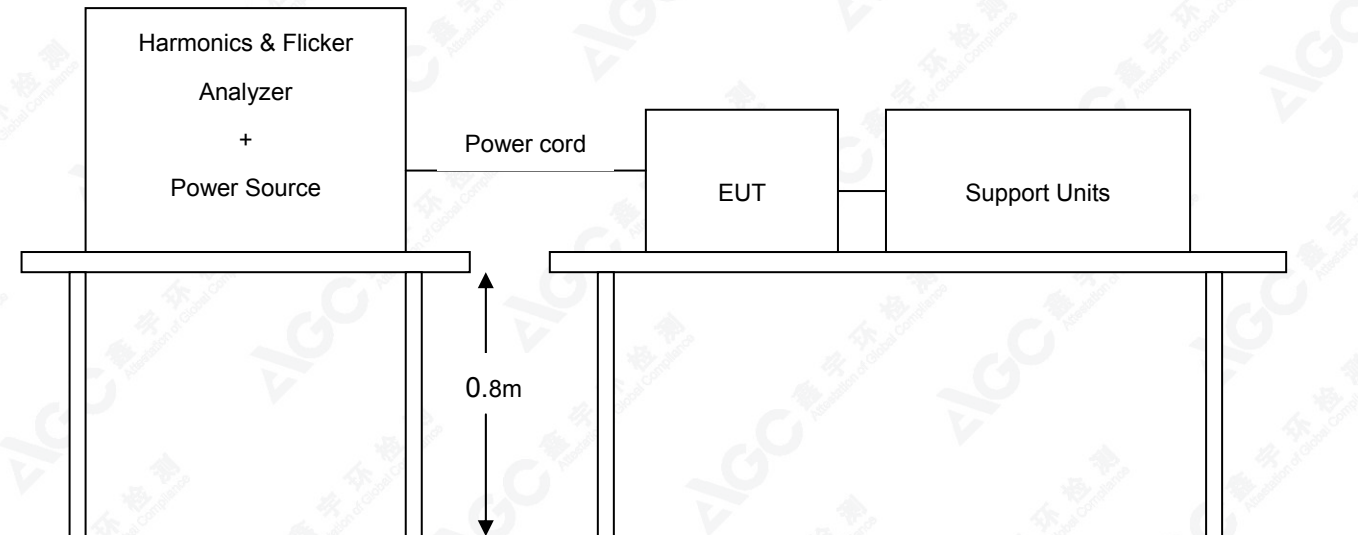

**9.2. RESULT**

**Note:** Owing to the power of EUT is less than 75W, so test is not applicable.

The results shown in this test report refer only to the sample(s) tested unless otherwise stated and the sample(s) are retained for 30 days only. The document is issued by AGC, this document cannot be reproduced except in full with our prior written permission. The document is available on request and the brief information for its validation can be assessable and confirmed at <http://www.agc-cert.com>



**10. EN 61000-3-3 VOLTAGE FLUCTUATION / FLICKER TEST**  
**VOLTAGE FLUCTUATION/FLICKER MEASUREMENT**

<b>Port</b>	AC mains
<b>Basic Standard</b>	EN 61000-3-3
<b>Limits</b>	§5 of EN 61000-3-3
<b>Tester:</b>	Max
<b>Temperature</b>	25°C
<b>Humidity</b>	55%

**10.1. BLOCK DIAGRAM OF TEST SETUP**

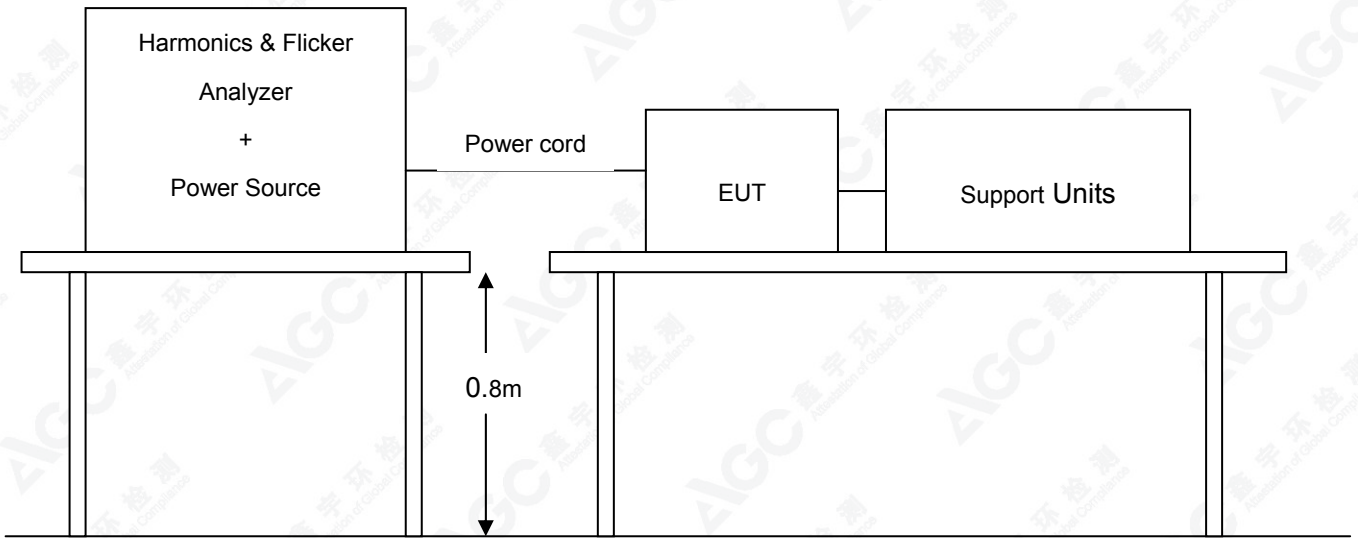

The results shown in this test report refer only to the sample(s) tested unless otherwise stated and the sample(s) are retained for 30 days only. The document is issued by AGC, this document cannot be reproduced except in full with our prior written permission. The document is available on request and the brief information for its validation can be assessable and confirmed at <http://www.agc-cert.com>



**10.2. RESULT**

**Flicker Test Summary per EN/IEC61000-3-3 (Run time)**

EUT: A41W Tested by: Max  
 Test category: All parameters (European limits) Test Margin: 100  
 Test date: 07-22-2016 Start time: 11:22:01 End time: 11:32:23  
 Test duration (min): 10 Data file name: F-000249.cts\_data  
 Comment: Normal operation mode  
 Test Result: Pass Status: Test Completed

Pst and limit line

European Limits

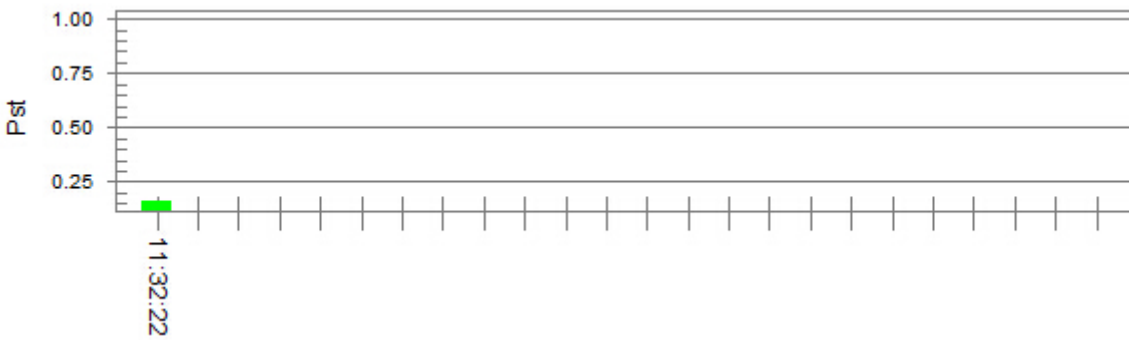

Plt and limit line

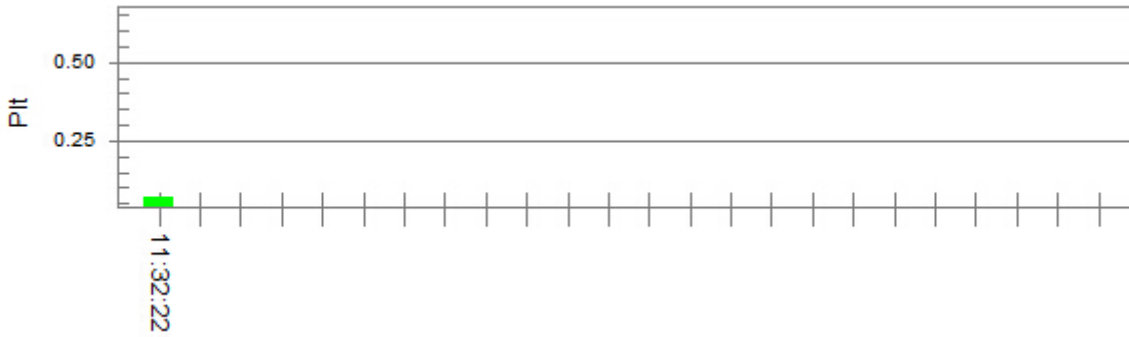

Parameter values recorded during the test:

Vrms at the end of test (Volt):	230.74			
Highest dt (%):	0.00	Test limit (%):	3.30	Pass
Time(mS) > dt:	0.0	Test limit (mS):	500.0	Pass
Highest dc (%):	0.00	Test limit (%):	3.30	Pass
Highest dmax (%):	0.00	Test limit (%):	4.00	Pass
Highest Pst (10 min. period):	0.160	Test limit:	1.000	Pass
Highest Plt (2 hr. period):	0.070	Test limit:	0.650	Pass

The results shown in this test report refer only to the sample(s) tested unless otherwise stated and the sample(s) are retained for 30 days only. The document is issued by AGC, this document cannot be reproduced except in full with our prior written permission. The document is available on request and the brief information for its validation can be assessable and confirmed at <http://www.agc-cert.com>



**11. EN 61000-4-2 ESD IMMUNITY TEST**  
**ELECTROSTATIC DISCHARGE (ESD) IMMUNITY TEST**

Port	Enclosure
Basic Standard	EN 61000-4-2
Test Level	± 8.0 kV (Air Discharge) ± 4.0 kV (Contact Discharge) ± 4.0 kV (Indirect Discharge)
Standard require	B
Tester	Max
Temperature	20°C
Humidity	50%

**11.1. BLOCK DIAGRAM OF TEST SETUP**

(The 470 k ohm resistors are installed per standard requirement)

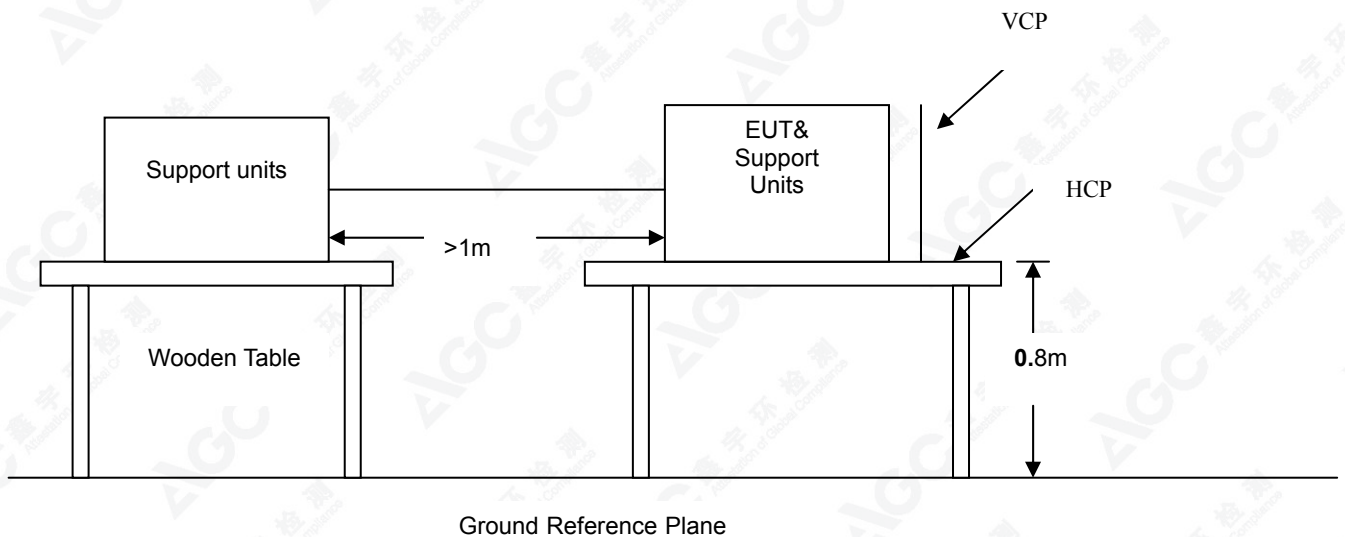

The results shown in this test report refer only to the sample(s) tested unless otherwise stated and the sample(s) are retained for 30 days only. The document is issued by AGC, this document cannot be reproduced except in full with our prior written permission. The document is available on request and the brief information for its validation can be assessable and confirmed at <http://www.agc-cert.com>



## 11.2. TEST PROCEDURE

The EUT was located 0.1 m minimum from all side of the HCP.

The support units were located 1 m minimum away from the EUT.

EUT worked with resistance load, and make sure EUT worked normally.

Active the communication function if the EUT with such port(s).

As per the requirement of EN 55024; applying direct contact discharge at the sides other than front of EUT at minimum 50 discharges (25 positive and 25 negative) if applicable, can't be applied direct contact discharge side of EUT then the indirect discharge shall be applied. One of the test points shall be subjected to at least 50 indirect discharge (contact) to the front edge of horizontal coupling plane.

Other parts of EUT where it is not possible to perform contact discharge then selecting appropriate points of EUT for air discharge, a minimum of 10 single air discharges shall be applied.

The application of ESD to the contact of open connectors is not required.

**Note:** As per the A2 to EN 61000-4-2, a bleed resistor cable is connected between the EUT and HCP during the test.

Yellow line: Air discharge

Red line: Contact discharge



The results shown in this test report refer only to the sample(s) tested unless otherwise stated and the sample(s) are retained for 30 days only. The document is issued by AGC, this document cannot be reproduced except in full with our prior written permission. The document is available on request and the brief information for its validation can be assessable and confirmed at <http://www.agc-cert.com>



Voltage	Coupling	Test Performance	Result (Criteria meet)
±4kV	Contact Discharge	No function loss	A
±4kV	Indirect Discharge HCP (Front)	No function loss	A
±4kV	Indirect Discharge HCP (Left)	No function loss	A
±4kV	Indirect Discharge HCP (Back)	No function loss	A
±4kV	Indirect Discharge HCP (Right)	No function loss	A
±4kV	Indirect Discharge VCP (Front)	No function loss	A
±4kV	Indirect Discharge VCP (Left)	No function loss	A
±4kV	Indirect Discharge VCP (Back)	No function loss	A
±4kV	Indirect Discharge VCP (Right)	No function loss	A
±8kV	Air Discharge	No function loss	A

### 11.3. PERFORMANCE & RESULT

<b>Criteria A:</b>	The apparatus continues to operate as intended. No degradation of performance or loss of function is allowed below a performance level specified by the manufacturer, when the apparatus is used as intended. In some cases the performance level may be replaced by a permissible loss of performance.
<b>Criteria B:</b>	The apparatus continues to operate as intended after the test. No degradation of performance or loss of function is allowed below a performance level specified by the manufacturer, when the apparatus is used as intended. In some cases the performance level may be replaced by a permissible loss of performance. During the test, degradation of performance is however allowed.
<b>Criteria C:</b>	Temporary loss of function is allowed, provided the functions self recoverable or can be restored by the operation of controls.

 **PASS**
 **FAIL**

The results shown in this test report refer only to the sample(s) tested unless otherwise stated and the sample(s) are retained for 30 days only. The document is issued by AGC, this document cannot be reproduced except in full with our prior written permission. The document is available on request and the brief information for its validation can be assessable and confirmed at <http://www.agc-cert.com>

**12. EN 61000-4-3 RS IMMUNITY TEST**  
**RADIATED ELECTROMAGNETIC FIELD IMMUNITY TEST**

Port	Enclosure
Basic Standard	EN 61000-4-3
Test Level:	3V/m with 80% AM. 1kHz Modulation.
Standard require	A
Tester	Max
Temperature	25°C
Humidity	55%

**12.1. BLOCK DIAGRAM OF TEST SETUP**

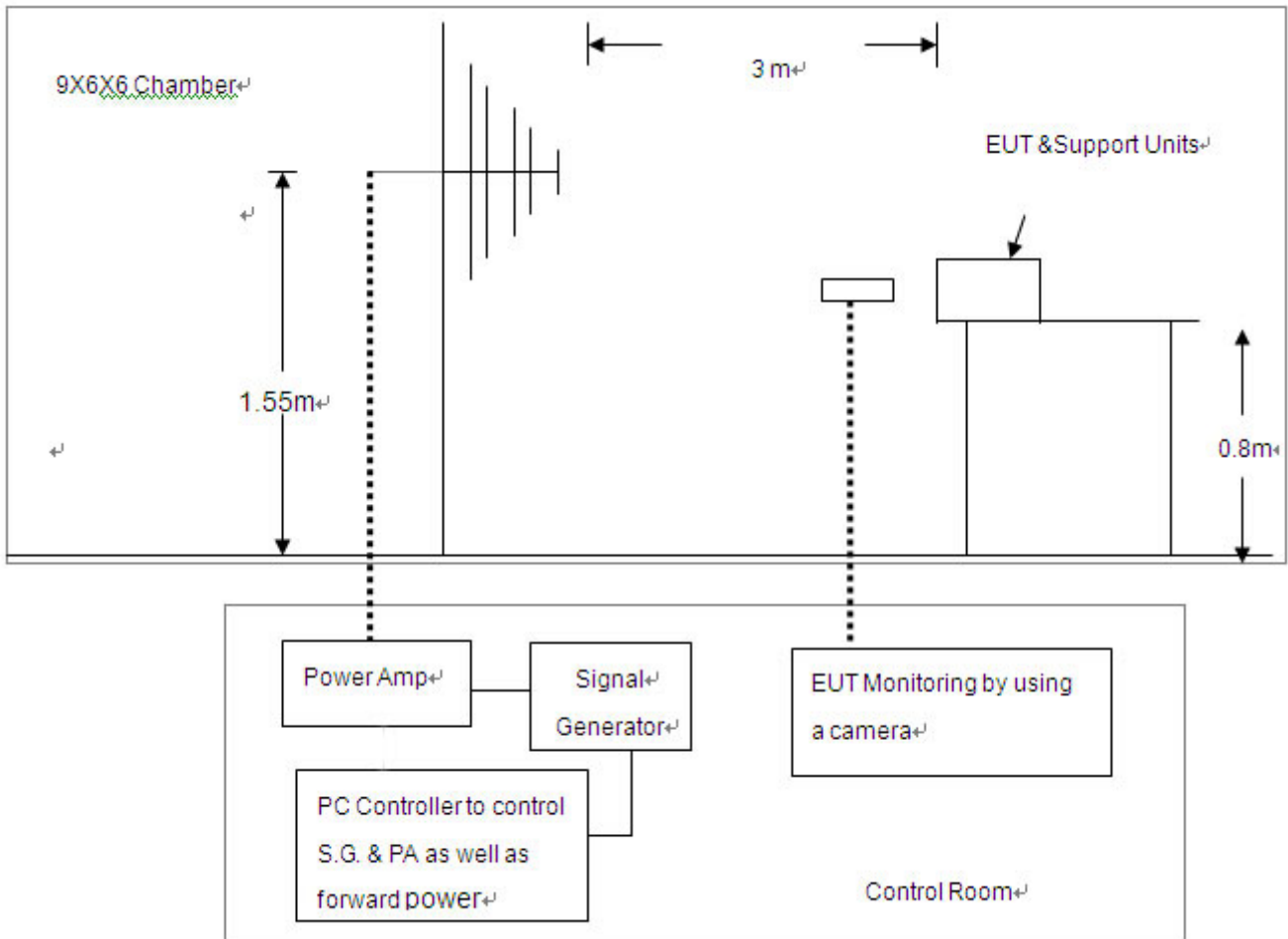

The results shown in this test report refer only to the sample(s) tested unless otherwise stated and the sample(s) are retained for 30 days only. The document is issued by AGC, this document cannot be reproduced except in full with our prior written permission. The document is available on request and the brief information for its validation can be assessable and confirmed at <http://www.agc-cert.com>

### 12.2. TEST PROCEDURE

The EUT was located at the edge of supporting table keep 3 meter away from transmitting antenna, it just the calibrated square area of field uniformity. The support units were located outside of the uniformity area, but the cable(s) connected with EUT were exposed to the calibrated field as per EN 61000-4-3.

EUT worked with resistance load, and make sure EUT worked normally.

Setting the testing parameters of RS test software per EN 61000-4-3.

Performing the test at each side of with specified level (3V/m) at 1% steps and test frequency from 80MHz to 1000MHz

Recording the test result in following table.

#### EN 61000-4-3 Final test conditions:

Test level: 3V/m

Steps: 1 % of fundamental

Dwell Time: 3 sec

Range (MHz)	Field	Modulation	Polarity	Position	Test Performance	Result (Criteria meet)
80-1000	3V/m	AM	H	Front	No function loss	A
80-1000	3V/m	AM	H	Left	No function loss	A
80-1000	3V/m	AM	H	Back	No function loss	A
80-1000	3V/m	AM	H	Right	No function loss	A
80-1000	3V/m	AM	V	Front	No function loss	A
80-1000	3V/m	AM	V	Left	No function loss	A
80-1000	3V/m	AM	V	Back	No function loss	A
80-1000	3V/m	AM	V	Right	No function loss	A

### 12.3. PERFORMANCE & RESULT

<b>Criteria A:</b>	The apparatus continues to operate as intended. No degradation of performance or loss of function is allowed below a performance level specified by the manufacturer, when the apparatus is used as intended. In some cases the performance level may be replaced by a permissible loss of performance.
<b>Criteria B:</b>	The apparatus continues to operate as intended after the test. No degradation of performance or loss of function is allowed below a performance level specified by the manufacturer, when the apparatus is used as intended. In some cases the performance level may be replaced by a permissible loss of performance. During the test, degradation of performance is however allowed.
<b>Criteria C:</b>	Temporary loss of function is allowed, provided the functions self recoverable or can be restored by the operation of controls.

 **PASS**
 **FAIL**

The results shown in this test report refer only to the sample(s) tested unless otherwise stated and the sample(s) are retained for 30 days only. The document is issued by AGC, this document cannot be reproduced except in full with our prior written permission. The document is available on request and the brief information for its validation can be assessable and confirmed at <http://www.agc-cert.com>

### 13. EN 61000-4-4 EFT IMMUNITY TEST

#### ELECTRICAL FAST TRANSIENTS/BURST IMMUNITY TEST

Port	On Power Supply Lines ; On Telecommunication Port
Basic Standard	EN 61000-4-4
Test Level	+/- 1kV for Power Supply Lines; +/- 0.5kV for LAN Lines;
Standard require	B
Tester	Max
Temperature	25°C
Humidity	55%

#### 13.1. BLOCK DIAGRAM OF TEST SETUP

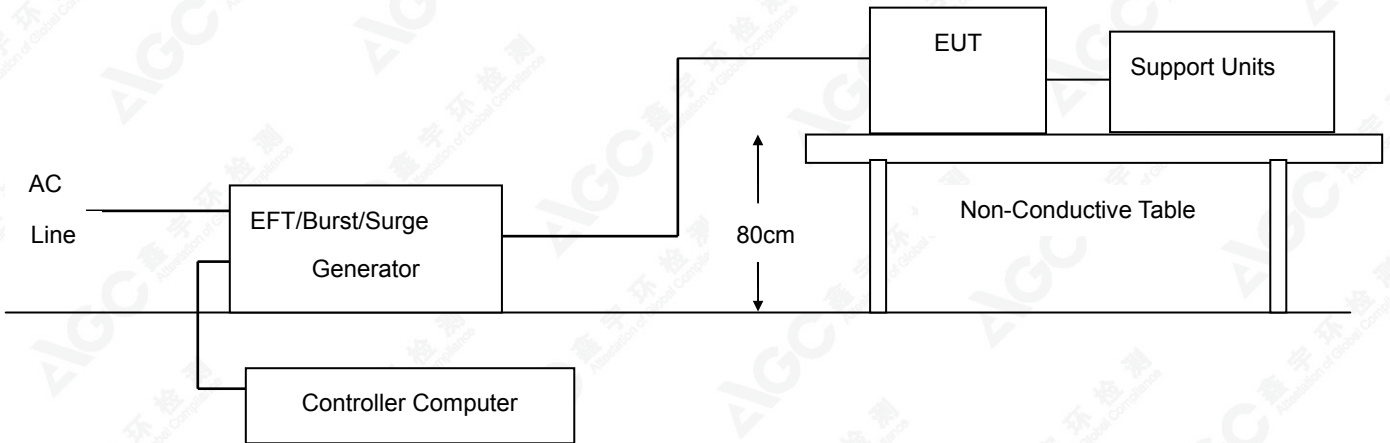

The results shown in this test report refer only to the sample(s) tested unless otherwise stated and the sample(s) are retained for 30 days only. The document is issued by AGC, this document cannot be reproduced except in full with our prior written permission. The document is available on request and the brief information for its validation can be assessable and confirmed at <http://www.agc-cert.com>

### 13.2. TEST PROCEDURE

The EUT and support units were located on a wooden table 0.8m away from ground reference plane.

A 1.0 meter long power cord was attached to EUT during the test.

The length of communication cable between communication port and clamp was keeping within 1 meter.

EUT worked with resistance load, and make sure EUT worked normally.

Related peripherals work during the test.

Recording the test result as shown in following table.

#### Test conditions:

Impulse Frequency: 5 kHz

Tr/Th: 5/50ns

Burst Duration: 15ms

Burst Period: 300ms

Inject Line	Voltage kV	Inject Method	Test Performance	Result (Criteria meet)
L+N	+/- 1	Direct	No function loss	A
LAN	+/- 0.5	Indirect	No function loss	A

### 13.3. PERFORMANCE & RESULT

<b>Criteria A:</b>	The apparatus continues to operate as intended. No degradation of performance or loss of function is allowed below a performance level specified by the manufacturer, when the apparatus is used as intended. In some cases the performance level may be replaced by a permissible loss of performance.
<b>Criteria B:</b>	The apparatus continues to operate as intended after the test. No degradation of performance or loss of function is allowed below a performance level specified by the manufacturer, when the apparatus is used as intended. In some cases the performance level may be replaced by a permissible loss of performance. During the test, degradation of performance is however allowed.
<b>Criteria C:</b>	Temporary loss of function is allowed, provided the functions self recoverable or can be restored by the operation of controls.

<input checked="" type="checkbox"/> <b>PASS</b> <input type="checkbox"/> <b>FAIL</b>
--

The results shown in this test report refer only to the sample(s) tested unless otherwise stated and the sample(s) are retained for 30 days only. The document is issued by AGC, this document cannot be reproduced except in full with our prior written permission. The document is available on request and the brief information for its validation can be assessable and confirmed at <http://www.agc-cert.com>



**14. EN 61000-4-5 SURGE IMMUNITY TEST**  
**SURGE IMMUNITY TEST**

<b>Port</b>	On Power Supply Lines ; On Telecommunication Port
<b>Basic Standard</b>	EN 61000-4-5
<b>Requirements</b>	+/- 1kV (Line to Line) On Power Supply Lines +/- 1kV (Line to Line) On LAN Lines
<b>Standard require</b>	B
<b>Tester</b>	Max
<b>Temperature</b>	25°C
<b>Humidity</b>	55%

**14.1. BLOCK DIAGRAM OF TEST SETUP**

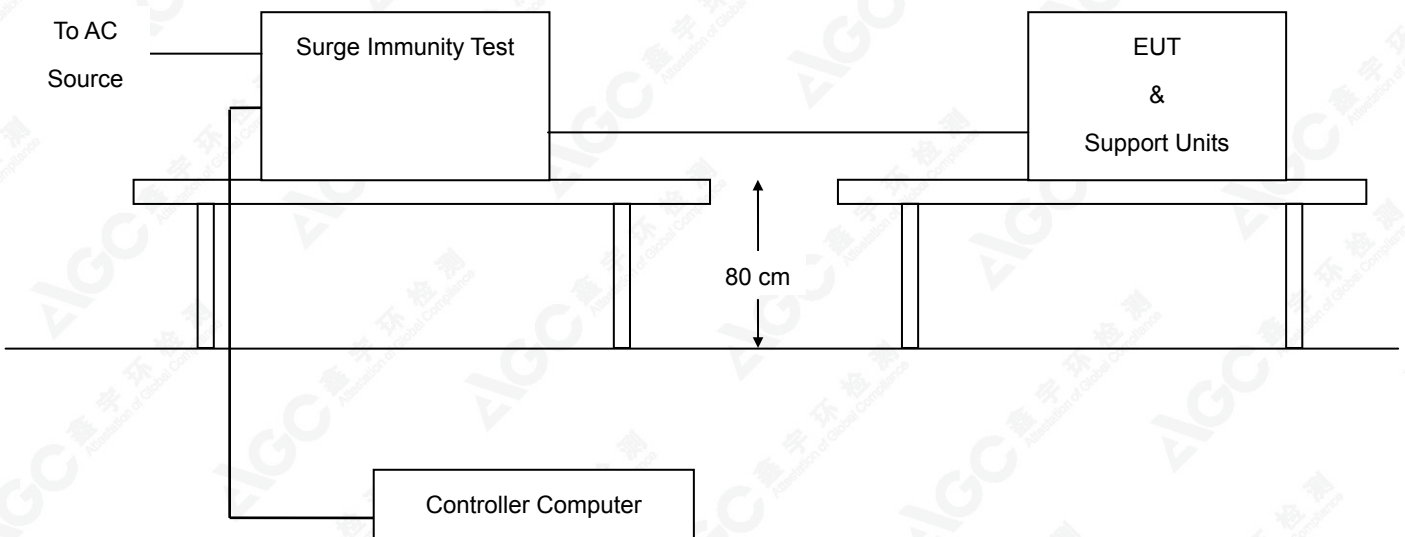

The results shown in this test report refer only to the sample(s) tested unless otherwise stated and the sample(s) are retained for 30 days only. The document is issued by AGC, this document cannot be reproduced except in full with our prior written permission. The document is available on request and the brief information for its validation can be assessable and confirmed at <http://www.agc-cert.com>



### 14.2. TEST PROCEDURE

The EUT and support units were located on a wooden table 0.8 m away from ground floor.

EUT worked with resistance load, and make sure EUT worked normally.

Recording the test result as shown in following table.

#### Test conditions for ac port

Voltage Waveform	1.2/50 us
Current Waveform	8/20 us
Polarity	Positive/Negative
Phase angle	0°, 180°, 90°, 270°
Number of Test	5

Coupling Line	Voltage (kV)	Polarity	Coupling Method	Test Performance	Result (Criteria meet)
L1-N	1	Positive	Capacitive	No function loss	A
L1-N	1	Negative	Capacitive	No function loss	A

#### Test conditions for LAN port

Voltage Waveform	10/700 us
Polarity	Positive/Negative
Number of Test	5

Coupling Line	Voltage (kV)	Polarity	Coupling Method	Test Performance	Result (Criteria meet)
LAN	1	Positive	Capacitive	No function loss	A
LAN	1	Negative	Capacitive	No function loss	A

### 14.3. PERFORMANCE & RESULT

<b>Criteria A:</b>	The apparatus continues to operate as intended. No degradation of performance or loss of function is allowed below a performance level specified by the manufacturer, when the apparatus is used as intended. In some cases the performance level may be replaced by a permissible loss of performance.
<b>Criteria B:</b>	The apparatus continues to operate as intended after the test. No degradation of performance or loss of function is allowed below a performance level specified by the manufacturer, when the apparatus is used as intended. In some cases the performance level may be replaced by a permissible loss of performance. During the test, degradation of performance is however allowed.
<b>Criteria C:</b>	Temporary loss of function is allowed, provided the functions self recoverable or can be restored by the operation of controls.

 **PASS**
 **FAIL**

**15. EN 61000-4-6 CS IMMUNITY TEST**

<b>Port</b>	On Power Supply Lines ; On Telecommunication Port
<b>Basic Standard</b>	EN 61000-4-6
<b>Requirements</b>	3V with 80% AM. 1 kHz Modulation
<b>Standard require</b>	A
<b>Tester</b>	Max
<b>Temperature</b>	25°C
<b>Humidity</b>	55%

**15.1. BLOCK DIAGRAM OF TEST SETUP**

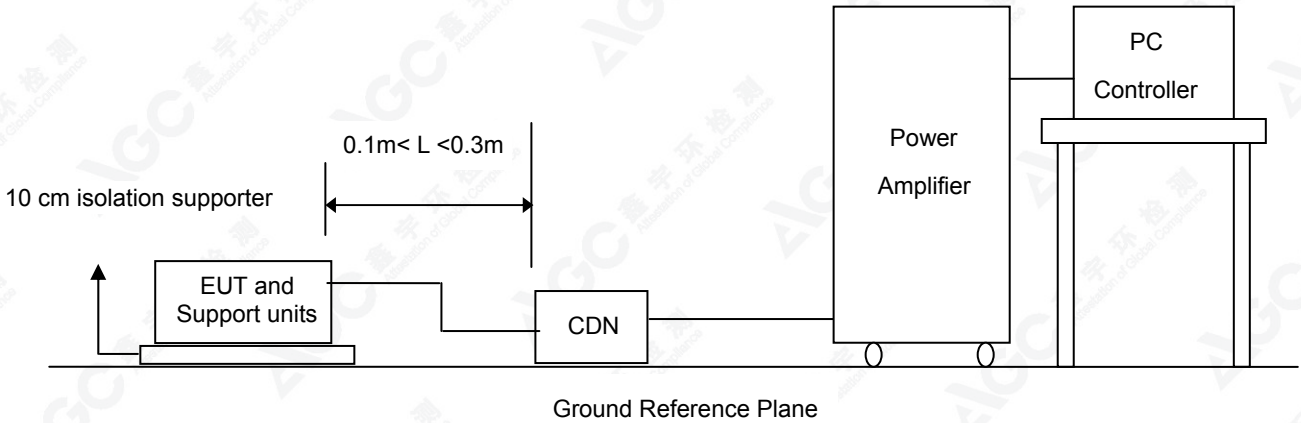

The results shown in this test report refer only to the sample(s) tested unless otherwise stated and the sample(s) are retained for 30 days only. The document is issued by AGC, this document cannot be reproduced except in full with our prior written permission. The document is available on request and the brief information for its validation can be assessable and confirmed at <http://www.agc-cert.com>





### 15.2. TEST PROCEDURE

The EUT and support units were located at a ground reference plane with the interposition of a 0.1 m thickness insulating support and the CDN was located on GRP directly.

EUT worked with resistance load, and make sure EUT worked normally.

Related peripherals work during the test.

Setting the testing parameters of CS test software per EN 61000-4-6.

Recording the test result in following table.

#### Test conditions:

<b>Frequency Range</b>	0.15MHz-80MHz
<b>Frequency Step</b>	1% of fundamental
<b>Dwell Time</b>	3 sec

#### AC port:

Range (MHz)	Strength	Modulation	Result (Criteria meet )
0.15-80	3V	AM	A

#### LAN port:

Range (MHz)	Strength	Modulation	Result (Criteria meet )
0.15-80	3V	AM	A

### 15.3. PERFORMANCE & RESULT

<b>Criteria A:</b>	The apparatus continues to operate as intended. No degradation of performance or loss of function is allowed below a performance level specified by the manufacturer, when the apparatus is used as intended. In some cases the performance level may be replaced by a permissible loss of performance.
<b>Criteria B:</b>	The apparatus continues to operate as intended after the test. No degradation of performance or loss of function is allowed below a performance level specified by the manufacturer, when the apparatus is used as intended. In some cases the performance level may be replaced by a permissible loss of performance. During the test, degradation of performance is however allowed.
<b>Criteria C:</b>	Temporary loss of function is allowed, provided the functions self recoverable or can be restored by the operation of controls.

<input checked="" type="checkbox"/> <b>PASS</b> <input type="checkbox"/> <b>FAIL</b>
--

The results shown in this test report refer only to the sample(s) tested unless otherwise stated and the sample(s) are retained for 30 days only. The document is issued by AGC, this document cannot be reproduced except in full with our prior written permission. The document is available on request and the brief information for its validation can be assessable and confirmed at <http://www.agc-cert.com>



**16. EN 61000-4-11 DIPS IMMUNITY TEST  
VOLTAGE DIPS, SHORT INTERRUPTIONS AND VOLTAGE VARIATIONS IMMUNITY TEST**

<b>Port</b>	On Power Supply Lines
<b>Basic Standard</b>	EN 61000-4-11
<b>Requirements</b>	0 degrees
<b>Test Interval</b>	Min. 10 sec.
<b>Tester</b>	Max
<b>Temperature</b>	25°C
<b>Humidity</b>	55%

Voltage Dips	Test Level % U <sub>T</sub>	Reduction (%)	Duration ( periods )	Performance Criteria
	<5	>95	0.5	B
	70	30	25	C

Voltage Interruptions	Test Level % U <sub>T</sub>	Reduction (%)	Duration ( periods )	Performance Criteria
	<5	>95	250	C

**16.1. BLOCK DIAGRAM OF TEST SETUP**

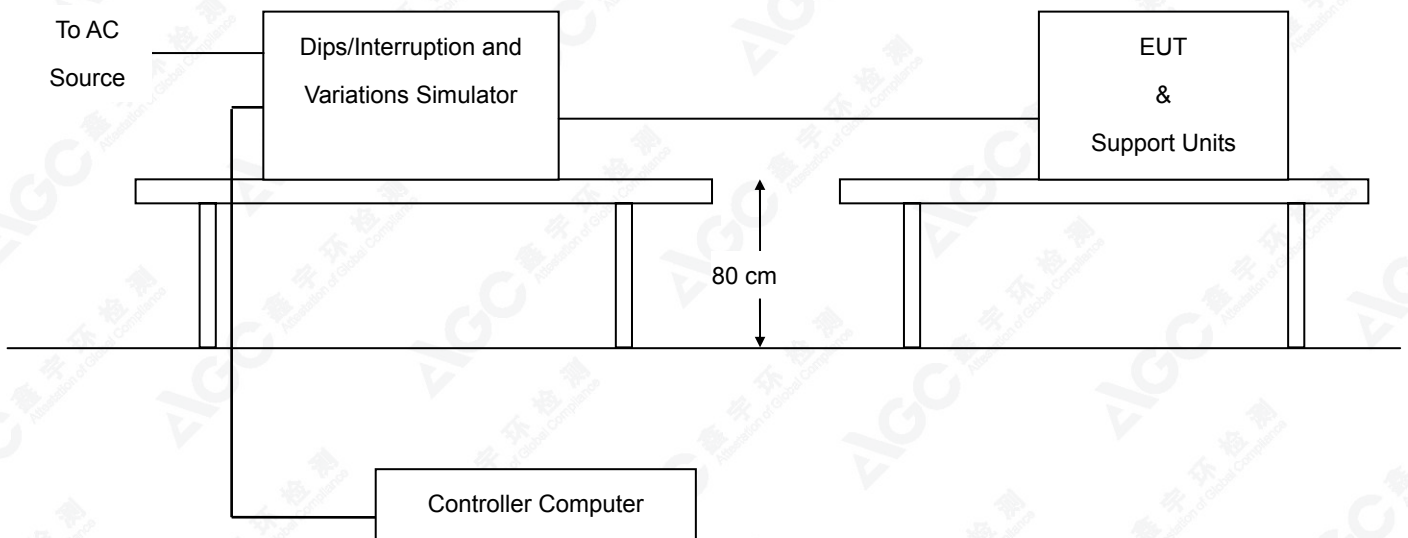

The results shown in this test report refer only to the sample(s) tested unless otherwise stated and the sample(s) are retained for 30 days only. The document is issued by AGC, this document cannot be reproduced except in full with our prior written permission. The document is available on request and the brief information for its validation can be assessable and confirmed at <http://www.agc-cert.com>

### 16.2. TEST PROCEDURE

The EUT and support units were located on a wooden table, 0.8 m away from ground floor.  
 EUT worked with resistance load, and make sure EUT worked normally.  
 Setting the parameter of tests and then perform the test software of test simulator.  
 Conditions changes to occur at 0 degree crossover point of the voltage waveform.  
 Recording the test result in test record form.

#### Test conditions:

The duration with a sequence of three dips/interruptions with interval of 10 s minimum  
 (Between each test event)

#### Voltage Dips:

Test Level % U <sub>T</sub>	Reduction (%)	Duration ( periods)	Performance Result
<5	>95	0.5	A
70	30	25	A

#### Voltage Interruptions:

Test Level % U <sub>T</sub>	Reduction (%)	Duration ( periods)	Performance Result
<5	>95	250	B

Performance B: The EuT Stopped charging during the test, but it can be recovered automatically after test.

### 16.3. INTERPRETATION

<b>Criteria A:</b>	The apparatus continues to operate as intended. No degradation of performance or loss of function is allowed below a performance level specified by the manufacturer, when the apparatus is used as intended. In some cases the performance level may be replaced by a permissible loss of performance.
<b>Criteria B:</b>	The apparatus continues to operate as intended after the test. No degradation of performance or loss of function is allowed below a performance level specified by the manufacturer, when the apparatus is used as intended. In some cases the performance level may be replaced by a permissible loss of performance. During the test, degradation of performance is however allowed.
<b>Criteria C:</b>	Temporary loss of function is allowed, provided the functions self recoverable or can be restored by the operation of controls.

<input checked="" type="checkbox"/> <b>PASS</b> <input type="checkbox"/> <b>FAIL</b>
--

The results shown in this test report refer only to the sample(s) tested unless otherwise stated and the sample(s) are retained for 30 days only. The document is issued by AGC, this document cannot be reproduced except in full with our prior written permission. The document is available on request and the brief information for its validation can be assessable and confirmed at <http://www.agc-cert.com>



**APPENDIX A: PHOTOGRAPHS OF TEST SETUP**  
**LINE CONDUCTED EMISSION TEST SETUP**  
**AT MAIN PORT**



AT COMMUNICATIO PORT



The results shown in this test report refer only to the sample(s) tested unless otherwise stated and the sample(s) are retained for 30 days only. The document is issued by AGC, this document cannot be reproduced except in full with our prior written permission. The document is available on request and the brief information for its validation can be assessed and confirmed at <http://www.agc-cert.com>

RADIATED EMISSION TEST SETUP

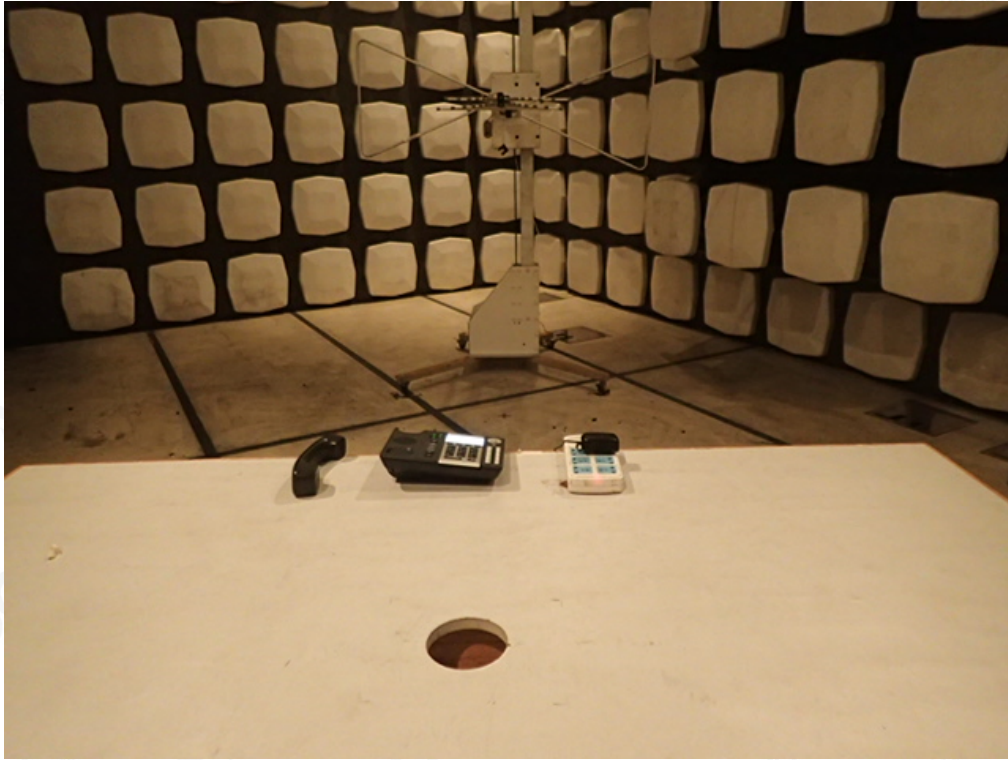

EN 61000-4-2 ESD TEST SETUP



The results shown in this test report refer only to the sample(s) tested unless otherwise stated and the sample(s) are retained for 30 days only. The document is issued by AGC, this document cannot be reproduced except in full with our prior written permission. The document is available on request and the brief information for its validation can be assessable and confirmed at <http://www.agc-cert.com>

EN61000-3-3 VOLTAGE FLUCTUATION / FLICKER TEST SETUP



EN 61000-4-3 RS TEST SETUP

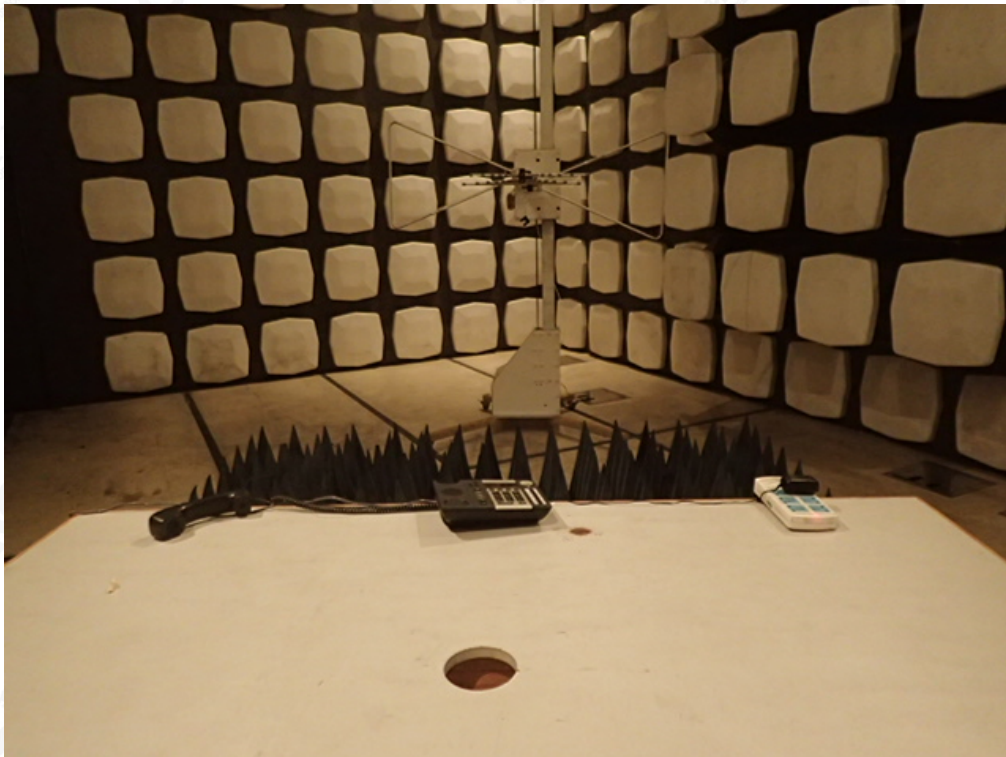

The results shown in this test report refer only to the sample(s) tested unless otherwise stated and the sample(s) are retained for 30 days only. The document is issued by AGC, this document cannot be reproduced except in full with our prior written permission. The document is available on request and the brief information for its validation can be assessable and confirmed at <http://www.agc-cert.com>

EN 61000-4-6 CS IMMUNITY TEST SETUP  
AT MAIN PORT

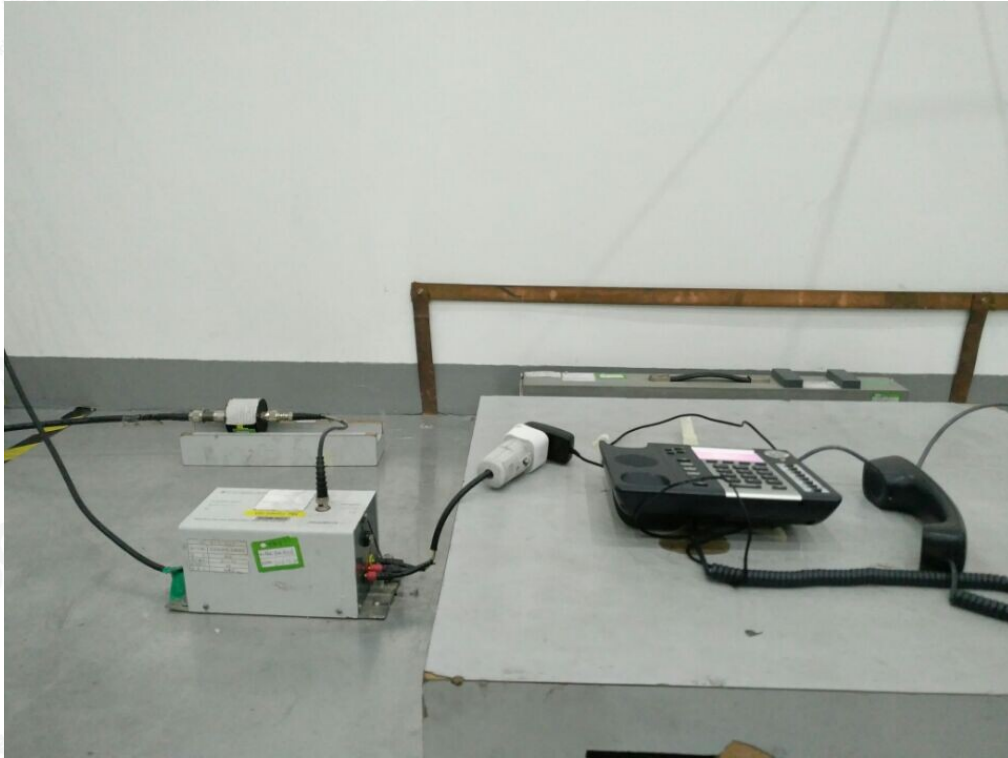

AT COMMUNICATIO PORT



The results shown in this test report refer only to the sample(s) tested unless otherwise stated and the sample(s) are retained for 30 days only. The document is issued by AGC, this document cannot be reproduced except in full with our prior written permission. The document is available on request and the brief information for its validation can be assessable and confirmed at <http://www.agc-cert.com>

EN 61000-4-4/-5/-11 EFT/SURGE/DIPS TEST SETUP



The results shown in this test report refer only to the sample(s) tested unless otherwise stated and the sample(s) are retained for 30 days only. The document is issued by AGC, this document cannot be reproduced except in full with our prior written permission. The document is available on request and the brief information for its validation can be assessable and confirmed at <http://www.agc-cert.com>





**APPENDIX B: PHOTOGRAPHS OF EUT**  
ALL VIEW OF EUT



TOP VIEW OF EUT



The results shown in this test report refer only to the sample(s) tested unless otherwise stated and the sample(s) are retained for 30 days only. The document is issued by AGC, this document cannot be reproduced except in full with our prior written permission. The document is available on request and the brief information for its validation can be assessable and confirmed at <http://www.agc-cert.com>

BOTTOM VIEW OF EUT



FRONT VIEW OF EUT



The results shown in this test report refer only to the sample(s) tested unless otherwise stated and the sample(s) are retained for 30 days only. The document is issued by AGC, this document cannot be reproduced except in full with our prior written permission. The document is available on request and the brief information for its validation can be assessable and confirmed at <http://www.agc-cert.com>

BACK VIEW OF EUT



LEFT VIEW OF EUT

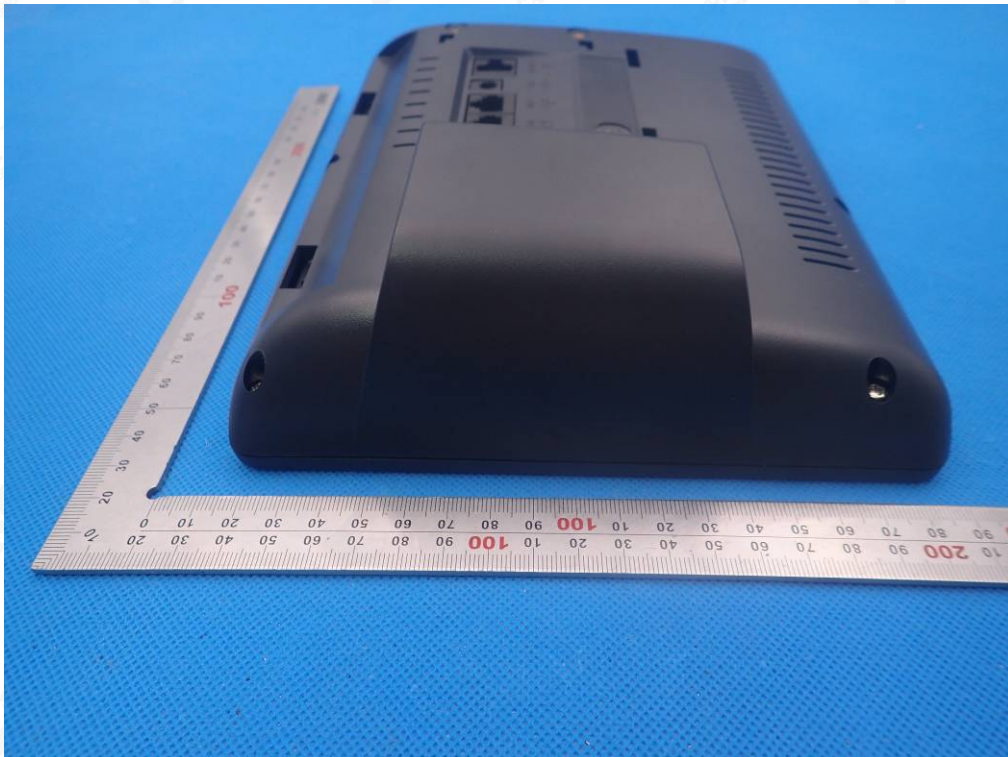

The results shown in this test report refer only to the sample(s) tested unless otherwise stated and the sample(s) are retained for 30 days only. The document is issued by AGC, this document cannot be reproduced except in full with our prior written permission. The document is available on request and the brief information for its validation can be assessable and confirmed at <http://www.agc-cert.com>

RIGHT VIEW OF EUT



OPEN VIEW OF EUT

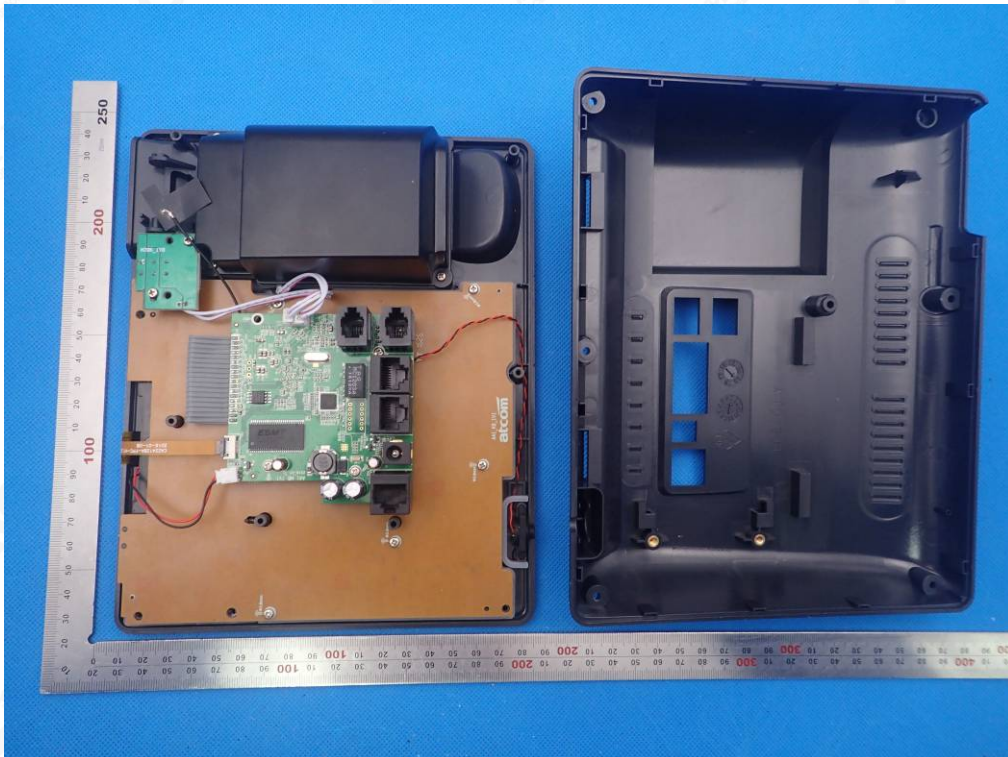

The results shown in this test report refer only to the sample(s) tested unless otherwise stated and the sample(s) are retained for 30 days only. The document is issued by AGC, this document cannot be reproduced except in full with our prior written permission. The document is available on request and the brief information for its validation can be assessable and confirmed at <http://www.agc-cert.com>

INTERNAL VIEW OF EUT-1

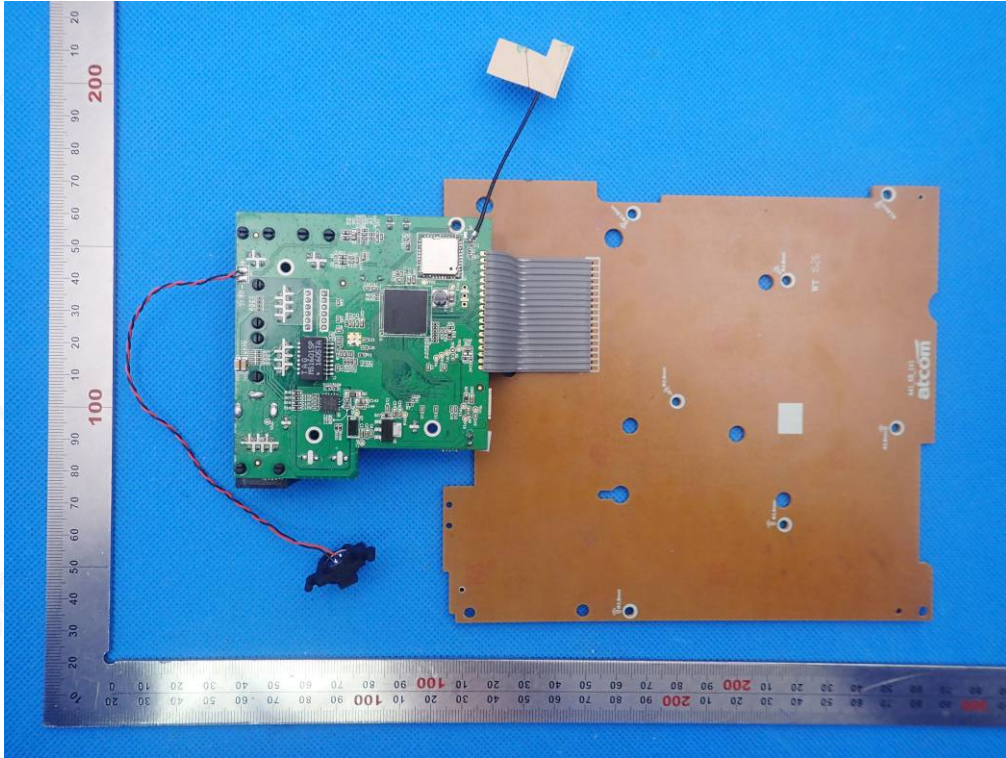

INTERNAL VIEW OF EUT-2

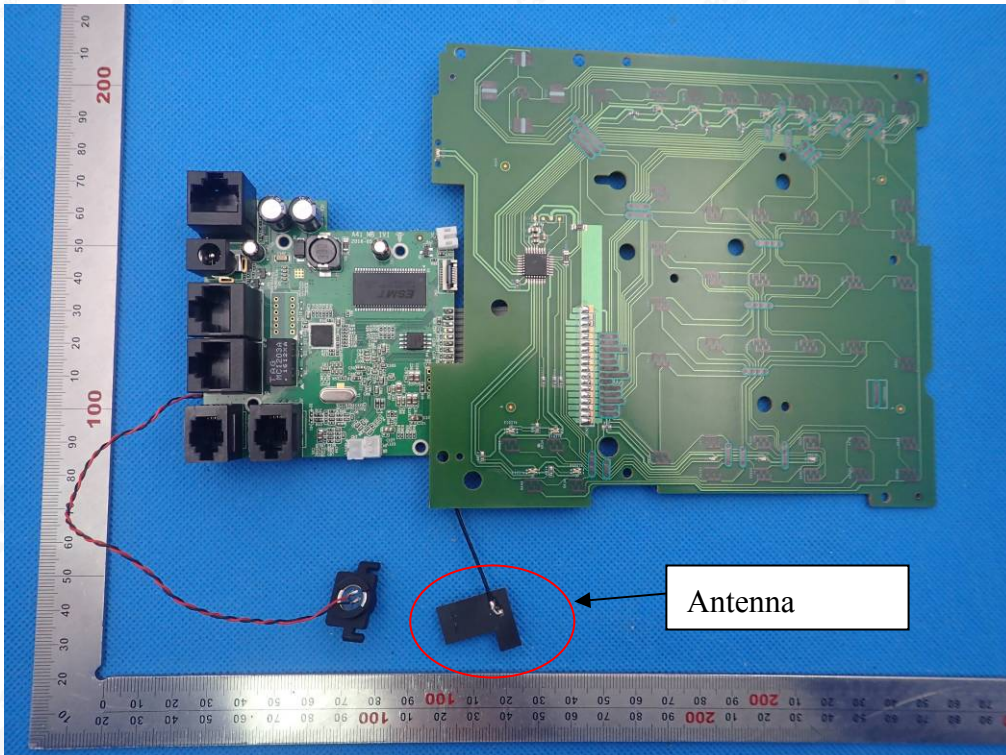

The results shown in this test report refer only to the sample(s) tested unless otherwise stated and the sample(s) are retained for 30 days only. The document is issued by AGC, this document cannot be reproduced except in full with our prior written permission. The document is available on request and the brief information for its validation can be assessable and confirmed at <http://www.agc-cert.com>

INTERNAL VIEW OF EUT-3

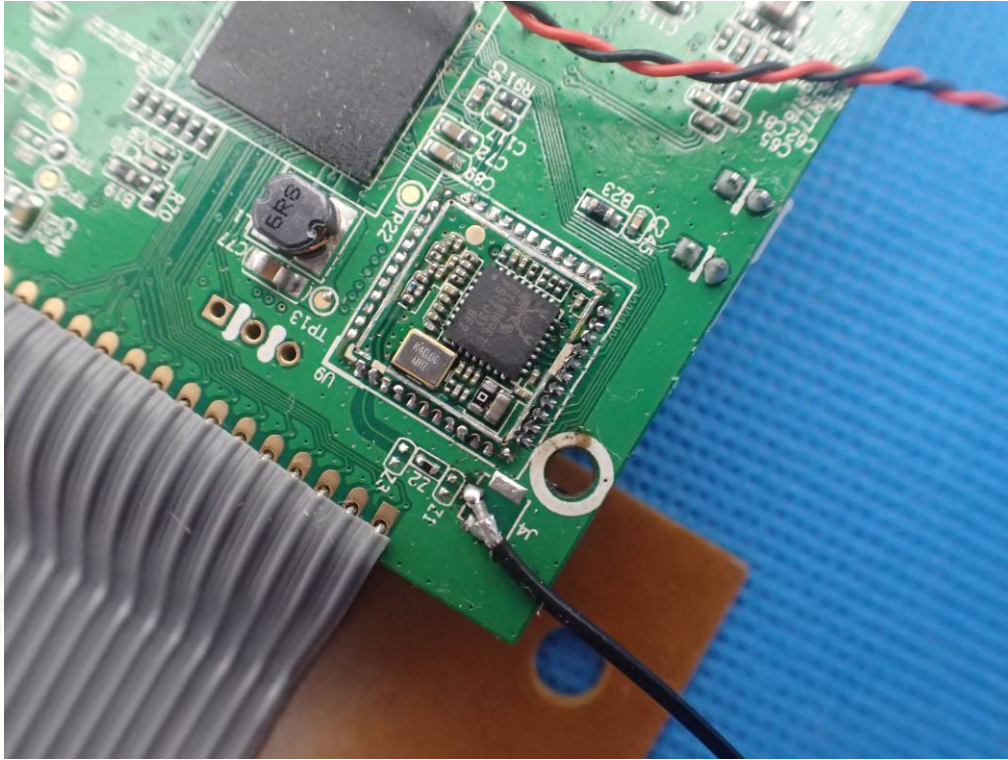

INTERNAL VIEW OF EUT-4

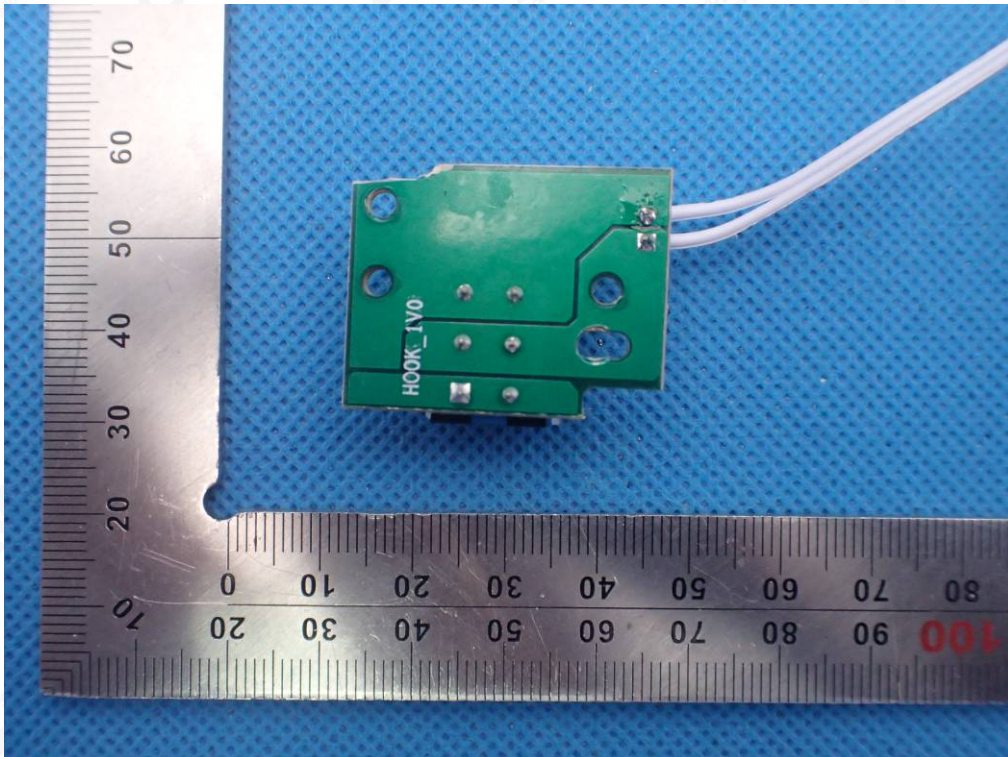

The results shown in this test report refer only to the sample(s) tested unless otherwise stated and the sample(s) are retained for 30 days only. The document is issued by AGC; this document cannot be reproduced except in full with our prior written permission. The document is available on request and the brief information for its validation can be assessable and confirmed at <http://www.agc-cert.com>

INTERNAL VIEW OF EUT-5

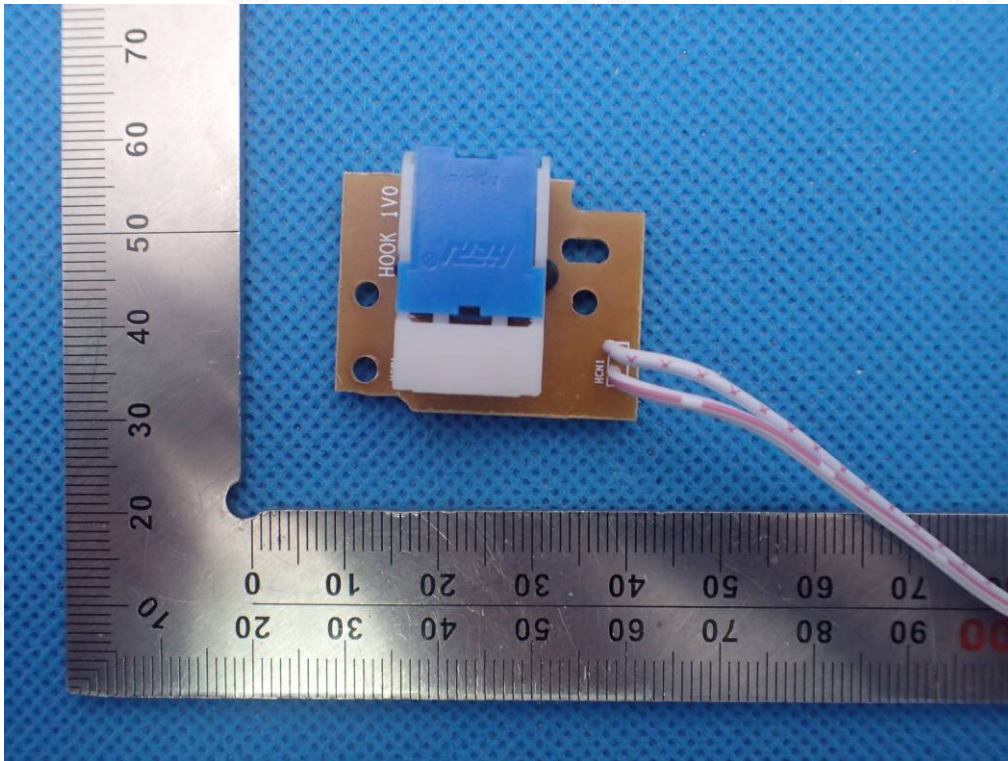

----END OF REPORT----

The results shown in this test report refer only to the sample(s) tested unless otherwise stated and the sample(s) are retained for 30 days only. The document is issued by AGC, this document cannot be reproduced except in full with our prior written permission. The document is available on request and the brief information for its validation can be assessable and confirmed at <http://www.agc-cert.com>